

-weishaupt-

# manual

Installation and operating instruction

---

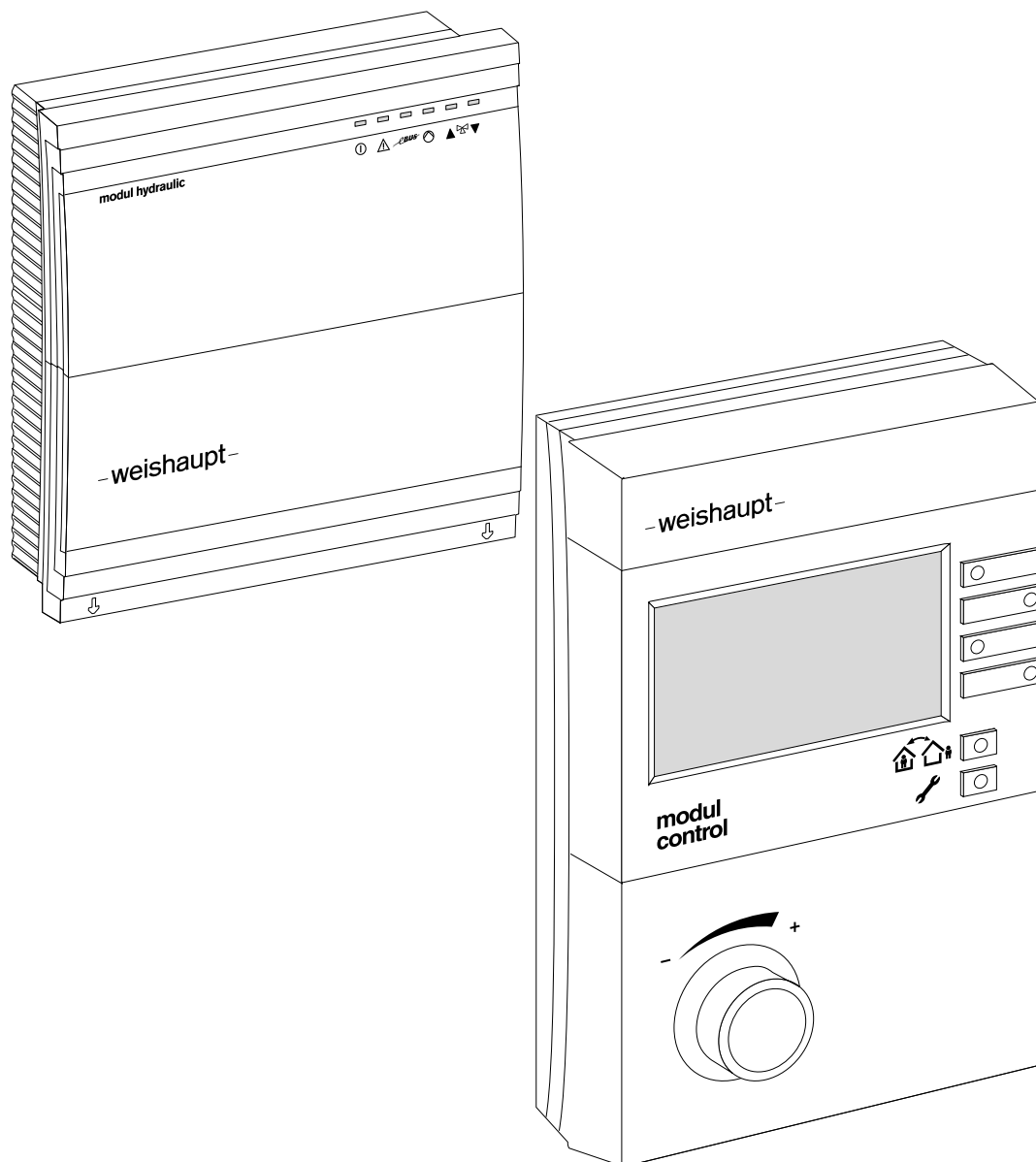

<b>1</b>	<b>User instructions</b>	<b>5</b>
1.1	User instructions	5
1.2	User guide	5
1.2.1	Symbols	5
1.2.2	Target group	5
1.3	Guarantee and Liability	5
<b>2</b>	<b>Safety</b>	<b>6</b>
2.1	Permissible application	6
2.2	Safety measures	6
2.3	Electrical connection	6
2.4	Disposal	6
<b>3</b>	<b>Product description</b>	<b>7</b>
3.1	Type key	7
3.2	Variations	8
3.2.1	Control with one pump heating circuit	8
3.2.2	Control of multiple heating circuits	9
3.2.3	Control with 2 separate heating circuits in one room	10
3.2.4	DHW preparation via WCM-EM	11
3.2.5	Control via control centre	12
3.2.6	Independent control with WCM-FS und WCM-EM	13
3.3	Technical data	14
3.3.1	Electrical data	14
3.3.2	Approval data	14
3.3.3	Ambient conditions	14
3.4	Compatibility	15
<b>4</b>	<b>Installation</b>	<b>16</b>
4.1	WCM-FS	16
4.2	WCM-EM	18
<b>5</b>	<b>Electrical installation</b>	<b>19</b>
5.1	WCM-FS	19
5.2	WCM-EM	20
5.2.1	Open housing cover	20
5.2.2	Connect WCM-EM	20
5.2.3	Connecting WCM-EM to condensing boiler	22
5.2.4	Wiring diagram WCM-EM as heating circuit controller	23
5.2.5	Wiring diagram WCM-EM as DHW load circuit	24
5.2.6	Connecting the pump shut off set to the WCM-EM	24
<b>6</b>	<b>Operation</b>	<b>25</b>
6.1	Operating panel WCM-FS 2.0	25
6.2	Standard display	26
6.3	Operating display of the WCM-EM	27
6.4	End user level	28
6.4.1	Menu structure end user level	30

6.5	Heating engineer level .....	32
6.5.1	Menu structure heating engineer level .....	34
6.5.2	Menu structure heating engineer level DHW .....	39
6.5.3	Menu structure heating engineer level control centre .....	40
6.5.4	Setting the language .....	42
6.5.5	Configuration of the WTC heat exchanger .....	43
6.5.6	Configuration WCM-EM .....	44
6.5.7	Set heating circuit type#1 ... 8 .....	45
6.5.8	Set control variable#1 ... 8 .....	47
6.5.9	Retrieving system information .....	48
6.5.10	Set function of variable input H1 .....	50
6.5.11	Test heating circuit/DHW outputs .....	51
6.5.12	Set external sensor correction on WCM-EM .....	52
6.5.13	Set minimum supply temperature .....	53
6.5.14	Set maximum supply temperature .....	54
6.5.15	Set priority of DHW loading .....	55
6.5.16	Set boiler mixer circuit boost .....	56
6.5.17	Set mixer parameters .....	57
6.5.18	Set frost protection .....	58
6.5.19	Set minimum pump speed .....	59
6.5.20	Set maximum pump speed .....	60
6.5.21	Set speed variables .....	61
6.5.22	Set WTC delay .....	62
6.5.23	SOL yield HC .....	63
6.5.24	Set screed program .....	65
6.5.25	Function specific heating .....	70
6.5.26	Screed heating .....	72
6.5.27	Set night setback operation .....	74
6.5.28	Set frost limit .....	75
6.5.29	Set switch on optimisation .....	76
6.5.30	Set type of building .....	77
6.5.31	Set room thermostat#1 ... 8 .....	78
6.5.32	Set adaption#1 ... 8 .....	79
6.5.33	Set room factor-P .....	80
6.5.34	Set maximum DHW temperature .....	81
6.5.35	Set DHW switch differential .....	82
6.5.36	Set DHW boost .....	83
6.5.37	Set maximum DHW load time .....	84
6.5.38	Set Legionella protection function .....	85
6.5.39	Set Antilegionella setpoint temperature .....	87
6.5.40	Set Legionella time .....	88
6.5.41	Activate circulation during Legionella protection function .....	89
6.5.42	Set circulation time .....	90
6.5.43	Set circulation return temperature .....	91
6.5.44	SOL Yield DHW .....	92
6.5.45	Central control via control centre .....	93
6.6	Extension module menu structure .....	95
6.6.1	Extension module EM-HC (access HC without FS) .....	95
6.6.2	Extension module EM-DHW (access HC without FS) .....	96

- 6.7      Reset WCM-EM ..... 97
- 6.8      Reconfiguring WCM-EM for system alterations ..... 97
- 6.9      Emergency operation WCM-EM ..... 97
- 6.10     Reset WCM-FS ..... 98
  
- 7    Commissioning ..... 99**
  - 7.1      Prerequisite ..... 99
  - 7.1.1    Set address on WCM-EM ..... 99
  - 7.2      Steps for commissioning ..... 100
  - 7.2.1    Setting the language ..... 100
  - 7.2.2    Set address on the WCM-FS ..... 101
  
- 8    Troubleshooting ..... 102**
  - 8.1      Error codes ..... 102
  
- 9    Technical documentation ..... 104**
  - 9.1      Sensor variables ..... 104
  
- 10   Key word index ..... 105**

**1 User instructions**

**1 User instructions**







**1.1 User instructions**

Translation of original  
operating instructions

These installation and operating instructions form part of the heating system and must be kept on site.

**1.2 User guide**

**1.2.1 Symbols**

 <b>DANGER</b>	Immediate danger with high risk. Non observance can lead to serious injury or death.
 <b>WARNING</b>	Danger with medium risk. Non observance can lead to environmental damage, serious injury or death.
 <b>CAUTION</b>	Danger with low risk. Non observance can cause damage to the equipment and injury to personnel.
	Important information.
	Requires direct action
	Result after an action
	Itemisation
...	Range

**1.2.2 Target group**

These installation and operating instructions are intended for the operator and qualified personnel. They should be observed by all personnel working on the system.

Work on the system must only be carried out by personnel who have the relevant training and instruction.

**1.3 Guarantee and Liability**

Guarantee and liability claims for personal and equipment damage are excluded, if they can be attributed to one or more of the following causes:

- Non approved application of the remote control station,
- non observance of the operating instructions,
- continual operation despite a fault,
- repairs, which have been carried out incorrectly,
- the use of non original Weishaupt parts,
- acts of God.

## 2 Safety

## 2 Safety

### 2.1 Permissible application

The remote control station WCM-FS 2.0 and the extension module WCM-EM 2.1 are suitable for the control of a heating system with up to 8 heating circuits (one direct heating circuit and 7 mixed heating circuits), consisting of one or more Weishaupt condensing boilers.



The connection of a Weishaupt solar controller WCM-SOL 1.0 home is possible.

---

This device is not intended for use by persons (including children) with reduced physical, sensory or mental capability or by persons lacking experience and/or knowledge, unless they are supervised by a person responsible for their safety or receive from this person instruction in how the device is used. Children should be supervised to ensure they do not play with the device.

Any use other than that described above shall be deemed improper. Weishaupt cannot be held responsible for any damage resulting from such use. The risk of such misuse lies entirely with the user. Correct use also includes compliance with the installation and operating manual and all other documents, which are included in the delivery in addition to these instructions.

The device described in these instructions conforms to the recognised level of technology and safety relevant regulations. Improper or inappropriate use could endanger the health and safety of the user or third party and impair the device function.

### 2.2 Safety measures

Safety relevant fault conditions must be eliminated immediately.

### 2.3 Electrical connection

For all work carried out on live parts:

- Observe the accident prevention instructions BGV A3 and adhere to local directives,
- tools in accordance with EN 60900 should be used.

### 2.4 Disposal

The remote control station WCM-FS and all WCM-EM and WCM-SOL connected must not be disposed of with household waste. Ensure the devices are disposed of in the correct manner.

The units are subject to the Act Governing the Sales, Return and Environmentally Sound Disposal of Electrical and Electronic Equipment (Electrical and Electronic Equipment-WEEE). Therefore free removal is provided at communal waste collection facilities.

### 3 Product description

### 3 Product description

#### 3.1 Type key

WCM	Type: Weishaupt Condens Manager
-FS	Model: Remote control station
2.0	Construction

---

WCM	Type: Weishaupt Condens Manager
-EM	Model: Extension module
2.1	Construction

### 3 Product description

### 3.2 Variations

#### 3.2.1 Control with one pump heating circuit

When controlling a pump heating circuit, the heating circuit pump is controlled by the WCM-FS address  $WTC-HC\#1$ . For the operation of the heating pump parameter P13 (MFA) or parameter P14 (VA) on the WTC must be set to parameter value 7.

In the following system example the WCM-FS is the time master and controls:

- Heating circuit #1
- DHW loading

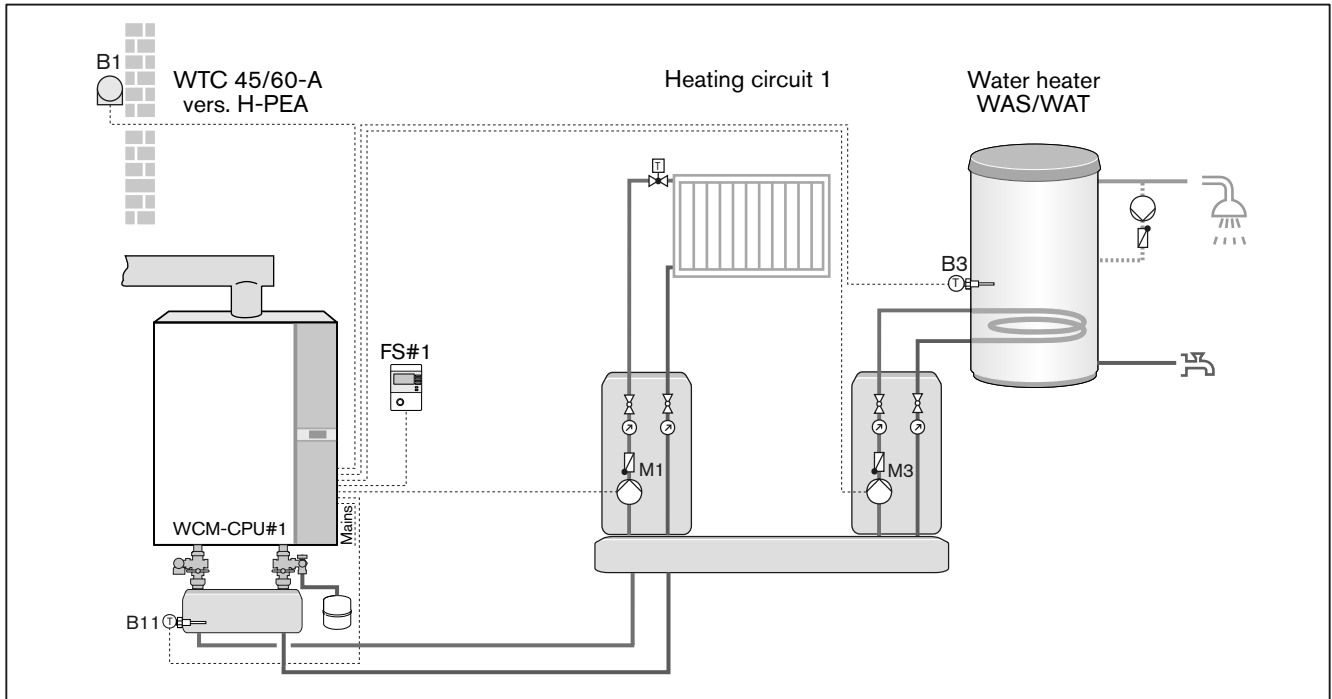

Legend:

- |      |                                 |
|------|---------------------------------|
| FS#1 | Remote control station WCM-FS#1 |
| B1:  | External sensor                 |
| B3:  | DHW sensor                      |
| B11: | De-couple sensor                |
| M1:  | Pump heating circuit 1 on MFA   |
| M3:  | Storage tank charge pump on VA  |

Note:

1. The remote control station FS must not be replaced with a DU timer.
2. DHW preparation always has priority.
3. Set address of the WCM-FS when commissioning:  $WTC-HK\#1$
4. WTC settings: P13=7, P14=4

### 3 Product description

#### 3.2.2 Control of multiple heating circuits

Up to 7 additional heating circuits can be controlled via separate extension modules. In the following system example the WCM-FS controls the respective heating circuit. Only the WCM-FS with address EM-HC#2 is time master and in the system example it controls:

- DHW loading
- Optional circulation pump.

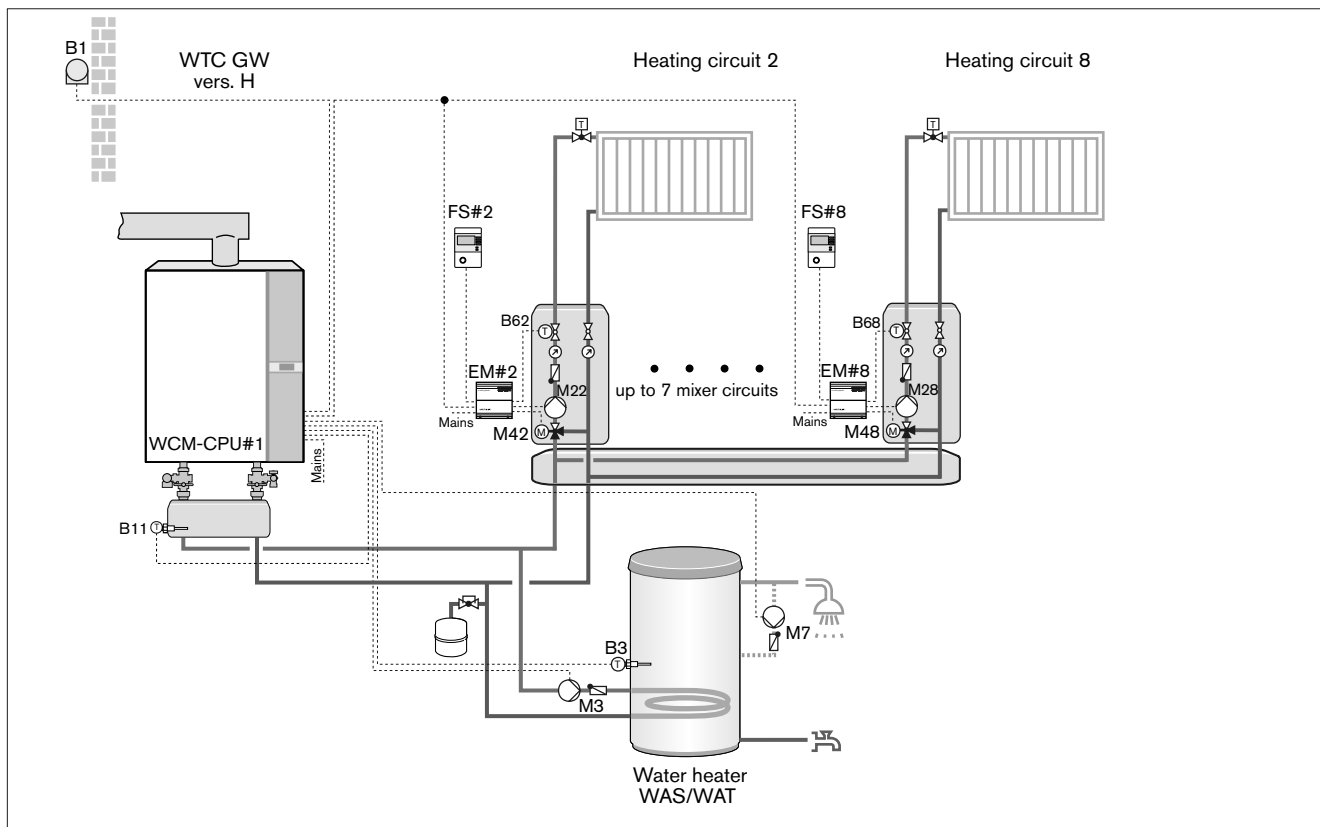

Legend:

- FS#2 ... 8: Remote control station WCM-FS#2 ... 8
- EM#2 ... 8: Extension module WCM-EM#2 ... 8
- B1: External sensor
- B3: DHW sensor
- B11: De-couple sensor
- B62: Supply sensor heating circuit 2
- B68: Supply sensor heating circuit 8
- M3: Storage tank charge pump on MFA
- M7: Circulation pump on VA
- M22: Pump heating circuit 2
- M28: Pump heating circuit 8
- M42: Mixer valve heating circuit 2
- M48: Mixer valve heating circuit 8

Note:

1. WTC settings: P13=4, P14=6

### 3 Product description

#### 3.2.3 Control with 2 separate heating circuits in one room

A room with 2 heating circuits is controlled via address  $WTC-HC\#1+EM-HC\#2$ .

Only the pump circuit can be controlled via room sensor. The heating circuit with the lowest temperature level, e.g. underfloor heating, must be controlled by the mixer valve.

The WCM-FS #1+2 is time master and controls the storage tank charge pump.

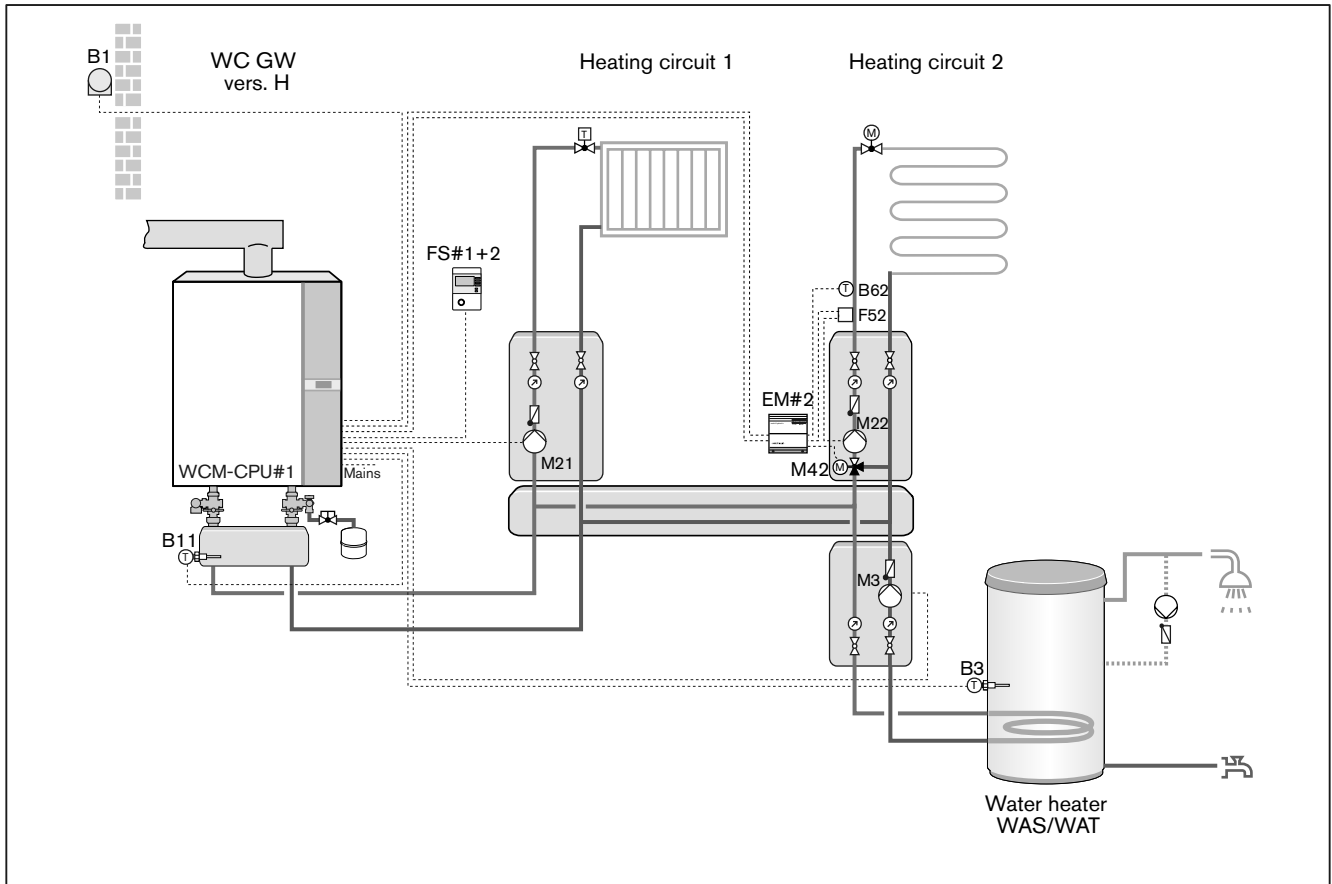

Legend:

- FS#1+2: Remote control station WCM-FS
- EM#2: Extension module WCM-EM
- B1: External sensor
- B3: DHW sensor
- B11: De-couple sensor
- B62: Supply sensor heating circuit 2
- M21: Pump heating circuit 1 on MFA
- M3: Storage tank charge pump on VA
- M22: Pump heating circuit 2
- M42: Mixer valve heating circuit 2
- M52: Temperature sensor underfloor heating

Note:

1. WTC settings: P13=7, P14=4

### 3 Product description

#### 3.2.4 DHW preparation via WCM-EM

It is possible to control multiple independent DHW load circuits.

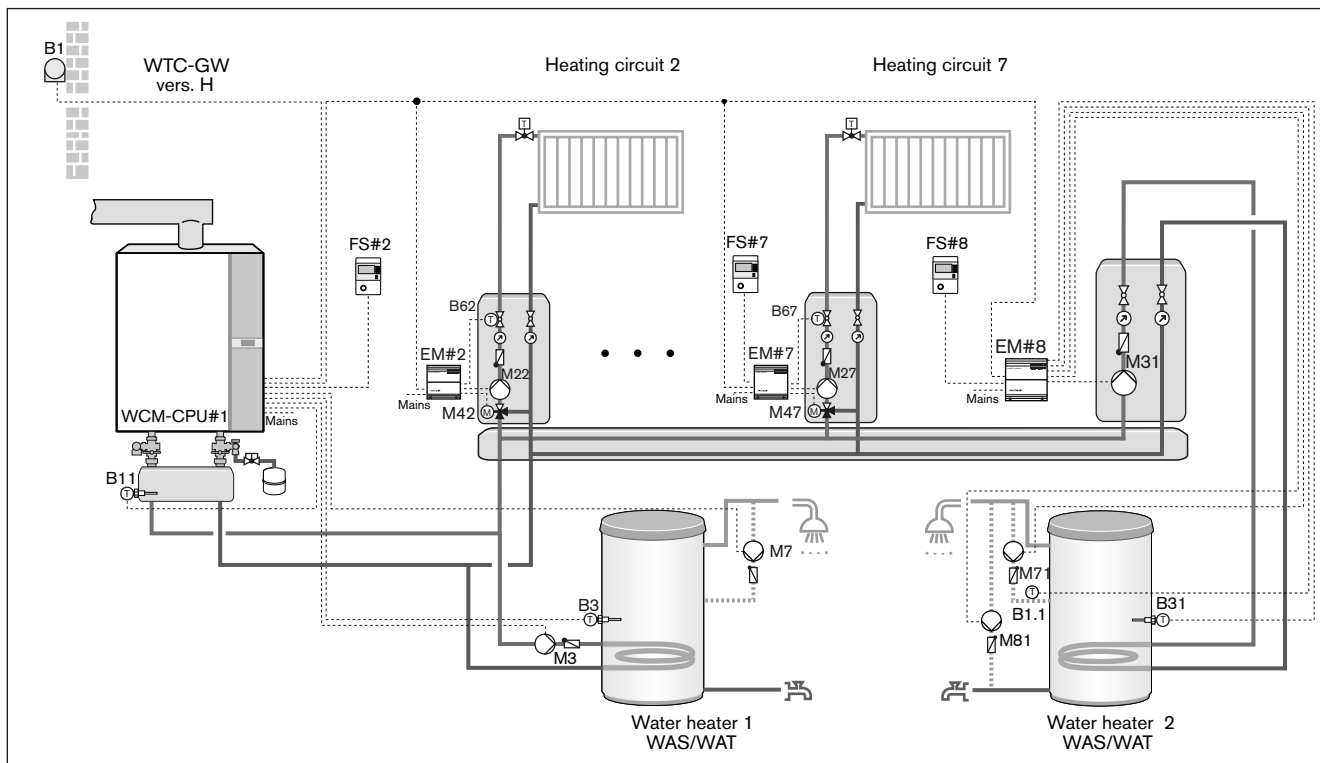

Legend:

- FS#2: Remote control station WCM-FS funct. heating circuit 2
- FS#7: Remote control station WCM-FS funct. heating circuit 7
- FS#8: Remote control station WCM-FS funct. DHW load circuit
- EM#2-8: Extension module WCM-EM
- B1: External sensor
- B1.1: Circulation sensor tank 2
- B3: DHW sensor tank 1
- B11: De-couple sensor
- B31: DHW sensor EM#8
- B62: Supply sensor heating circuit 2
- B67: Supply sensor heating circuit 7
- M3: Storage tank charge pump on MFA tank 1
- M7: Circulation pump on VA tank 1
- M22: Pump heating circuit 2
- M27: Pump heating circuit 7
- M31: Storage tank charge pump on EM-WW tank 2
- M42: Mixer valve heating circuit 2
- M47: Mixer valve heating circuit 7
- M71: Circulation pump
- M81: Antilegionella bypass pump (thermal disinfection)

Note:

1. WTC settings: P13=4, P14=6

### 3 Product description

#### 3.2.5 Control via control centre

A WCM-FS remote control station addressed with control centre centralises the control of the circulation pump and DHW load pump, the synchronisation of the system time and the type of operation set (see Ch. 6.5.45). Room sensor and presence and absence keys have no function with when control is via control centre. The heating controller is inactive. Using the type of operation set by the control centre, the type of operation of all extension modules can be controlled without a remote control station assigned.

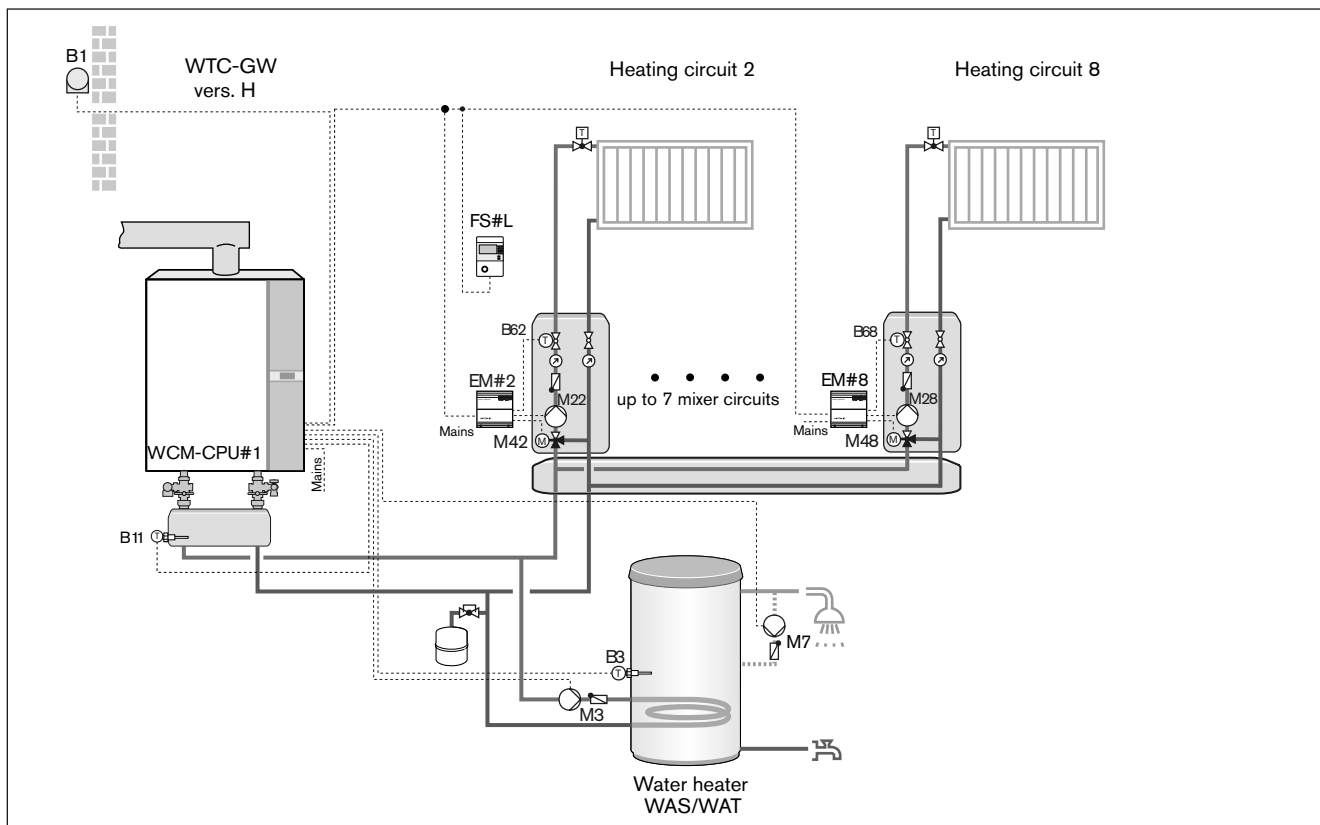

Legend:

- FS#L: Remote control station WCM-FS funct. control centre
- B1: External sensor
- B3: DHW sensor
- B11: De-couple sensor
- B62: Supply sensor heating circuit 2
- B68: Supply sensor heating circuit 8
- M3: Storage tank charge pump on MFA
- M7: Circulation pump on VA
- M22: Pump heating circuit 2
- M28: Pump heating circuit 8
- M42: Mixer valve heating circuit 2
- M48: Mixer valve heating circuit 8

Note:

1. WTC settings: P13=4, P14=6

### 3 Product description

#### 3.2.6 Independent control with WCM-FS und WCM-EM

The system's external sensor is connected to EM#2. The external temperature value is transmitted via eBUS to all remote control stations and extension modules connected.



A zone control with a locally connected external sensor is still possible.

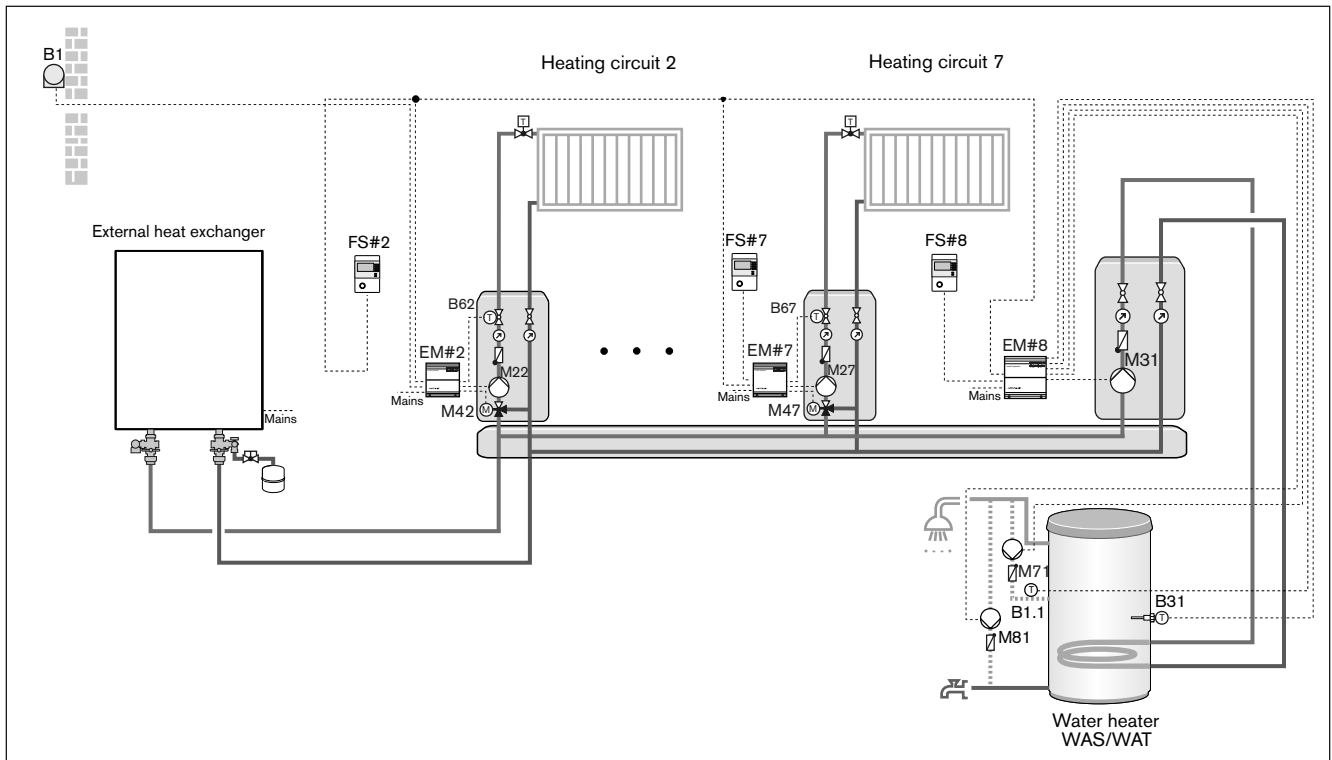

**Legend:**

- FS#2: Remote control station WCM-FS funct. heating circuit 2
- FS#7: Remote control station WCM-FS funct. heating circuit 7
- FS#8: Remote control station WCM-FS funct. DHW load circuit
- EM#2-8: Extension module WCM-EM
- B1: External sensor
- B1.1: Circulation sensor EM#8
- B31: DHW sensor EM#8
- B62: Supply sensor heating circuit 2
- B67: Supply sensor heating circuit 7
- M22: Pump heating circuit 2
- M27: Pump heating circuit 7
- M31: Storage tank charge pump EM#8
- M42: Mixer valve heating circuit 2
- M47: Mixer valve heating circuit 7
- M71: Circulation pump EM#8
- M81: Antilegionella bypass pump (thermal disinfection)

### 3 Product description

### 3.3 Technical data

#### 3.3.1 Electrical data

	WCM-FS	WCM-EM
Supply voltage / frequency	–	230 V/50 Hz
Max. consumption	–	7 VA
Max. prefusing	–	10 A
Internal unit fuse	–	6.3 A
Type of protection	–	IP 22
Protection class	II (to EN 60730)	I (to EN 60730)
Nominal current output MFA / MM1	–	max. 5 A* **

\* for electronic high efficiency pumps max 1.5 Ampere. Separate relay required for greater power consumptions.

\*\* Power consumption of outputs MFA 1 and MM1 in total maximal 5A.

#### 3.3.2 Approval data

Unit tested	to EN 60730
-------------	-------------

#### 3.3.3 Ambient conditions

Temperature in operation	0 °C ... 50 °C
Temperature during transport / storage	-25 ... 70 °C
relative humidity	max. 80 %, no dew point

### 3 Product description

#### 3.4 Compatibility

The WCM-FS 2.0 and WCM-EM 2.1 have functions, which were not provided by the previous WCM systems. Therefore there may be limited functionality with other WCM components.

The compatibility of each WCM component to one another is shown in the table below.

	WCM-FS 1.0	WCM-FS 2.0	WCM-EM 1.0	WCM-EM 2.0	WCM-EM 2.1	WCM-SOL 1.0	WCM-KA 1.0	WCM-KA 2.0
WCM-FS 1.0		C	A	A	B	B	A*	A*
WCM-FS 2.0	C		A	A	A	A	A	A
WCM-EM 1.0	A	A		C	C	B	A	A
WCM-EM 2.0	A	A	C		C	B	A	A
WCM-EM 2.1	B	A	C	C		A	A	A
WCM-SOL 1.0	B	A	B	B	A		D	D
WCM-KA 1.0	A	A	A	A	A	D		D
WCM-KA 2.0	A	A	A	A	A	D	D	

A	Full functionality
A*	Full functionality (from version WCM-FS 1.0 V196.27)
B	Compatible, the older component version limits the functionality
C	Can be used together in one system
D	Cannot be used in multiples/combined in one system

## 4 Installation

### 4 Installation

#### 4.1 WCM-FS

The room sensor integrated into the remote control station must not be influenced by:

- additional temperature control in the same room (radiator thermostats),
- other heat sources (direct sun light, chimney etc.).

► Install the remote control station to an inside wall on the opposite side to radiators.

#### Fitting the wall bracket

- Fix wall bracket to wall.
- Connect wiring (see Ch. 5.1).
- Clip remote control unit into the wall bracket.

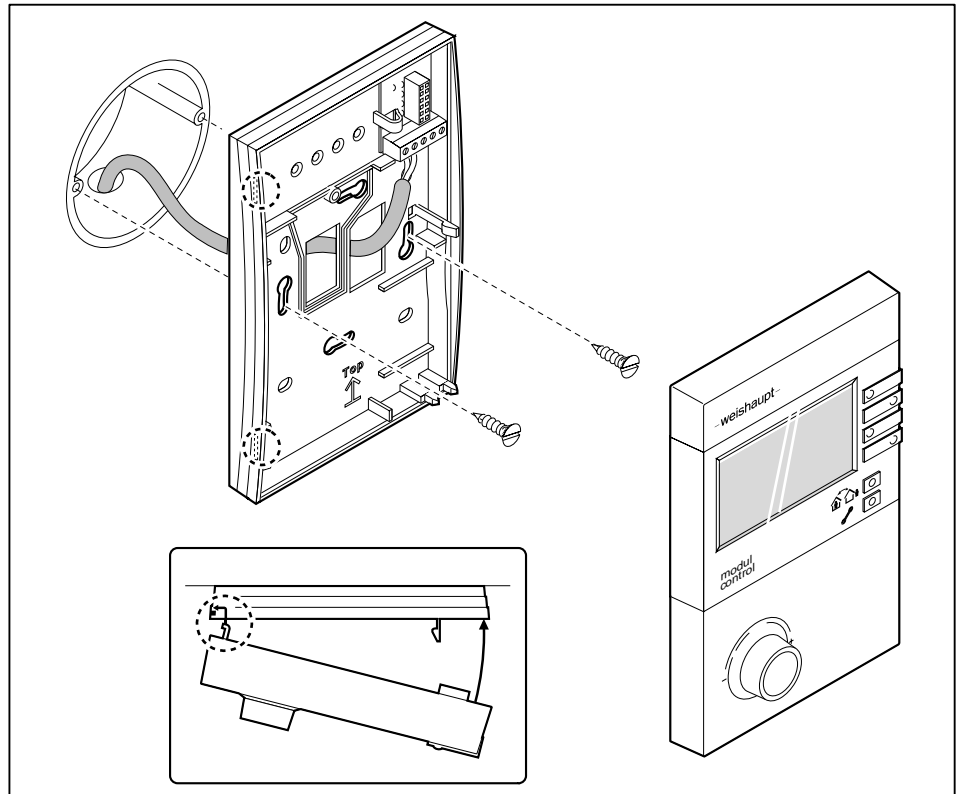

#### 4 Installation

##### Fitting the WCM-FS to a WTC-GW/OW

The mounting set available as an accessory is required.

- ▶ Install as instructed in the installation instructions supplied.

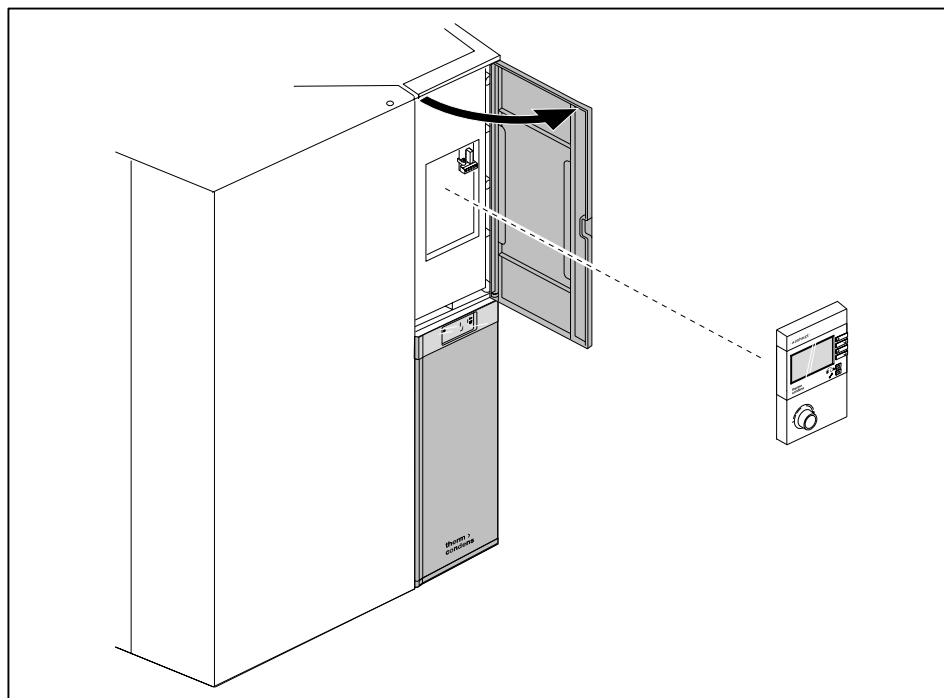

##### Fitting the WCM-FS to a WTC-GB/OB

- ▶ Open flap on boiler control panel.
- ▶ Clip remote control station into mounting slot.

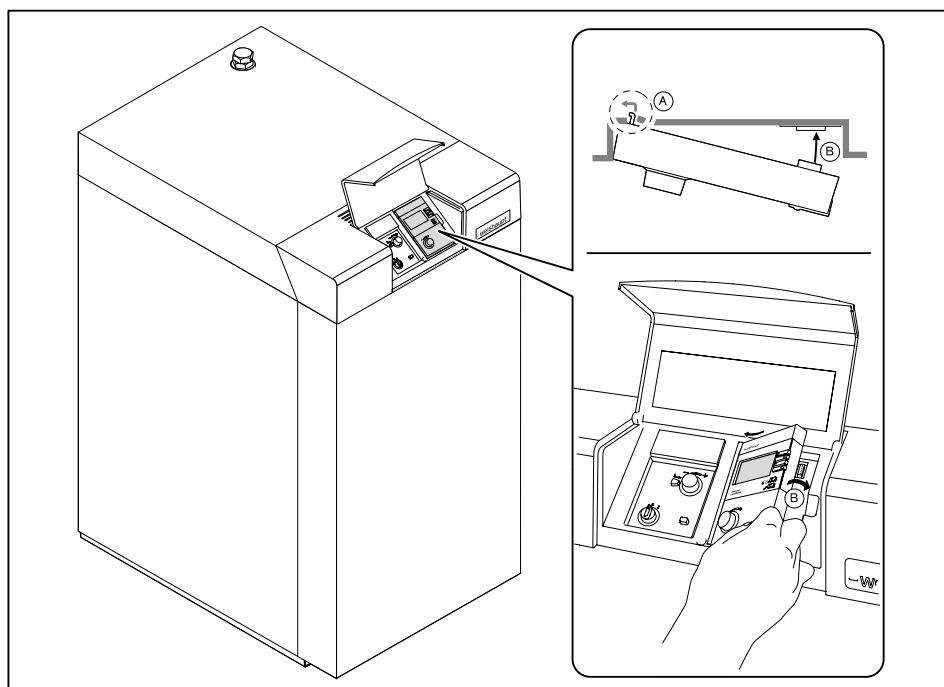

### 4 Installation



If the WCM-FS is fitted to a WTC, this is indicated in parameter Config FS with Boiler. The display of the room temperature in line 3 of the WCM-FS is omitted. A change in the location room<->boiler requires reconfiguration in parameter Config FS (P335).

#### 4.2 WCM-EM

- ▶ Fit cap type rail to the wall using suitable fixing material.
- ▶ Push in locking device ①.

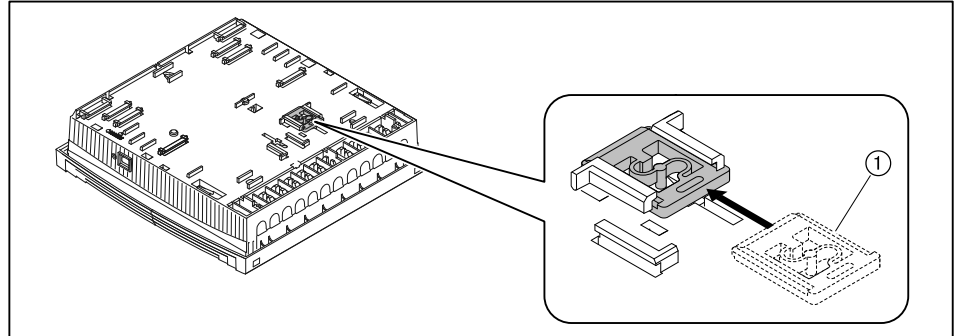

- ▶ Connect extension module to cap type rail.
- ▶ Connect cables (see Ch. 5.2).
- ▶ Close housing cover.

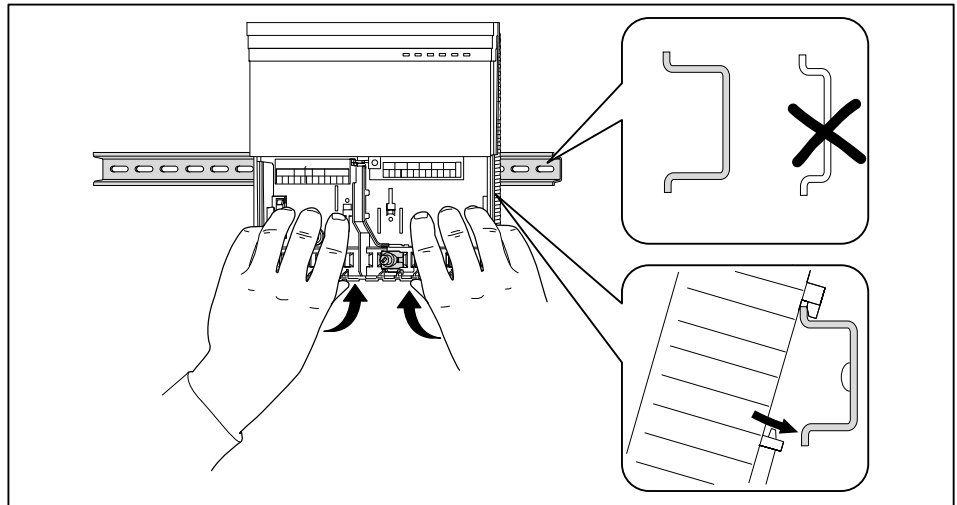

## 5 Electrical installation

### 5 Electrical installation

#### 5.1 WCM-FS



The WCM-FS 2.0 remote control station must only be assigned to a heating circuit with an extension module from WCM-EM 1.0.

- ▶ Connect electrical cable to eBUS terminal 1 and 2.
- ▶ An external room sensor can be fitted to terminals 5 and 6 if required (accessory).

Cable cross section	Max. length
1.5 mm <sup>2</sup>	1260 m
0.5 mm <sup>2</sup>	420 m

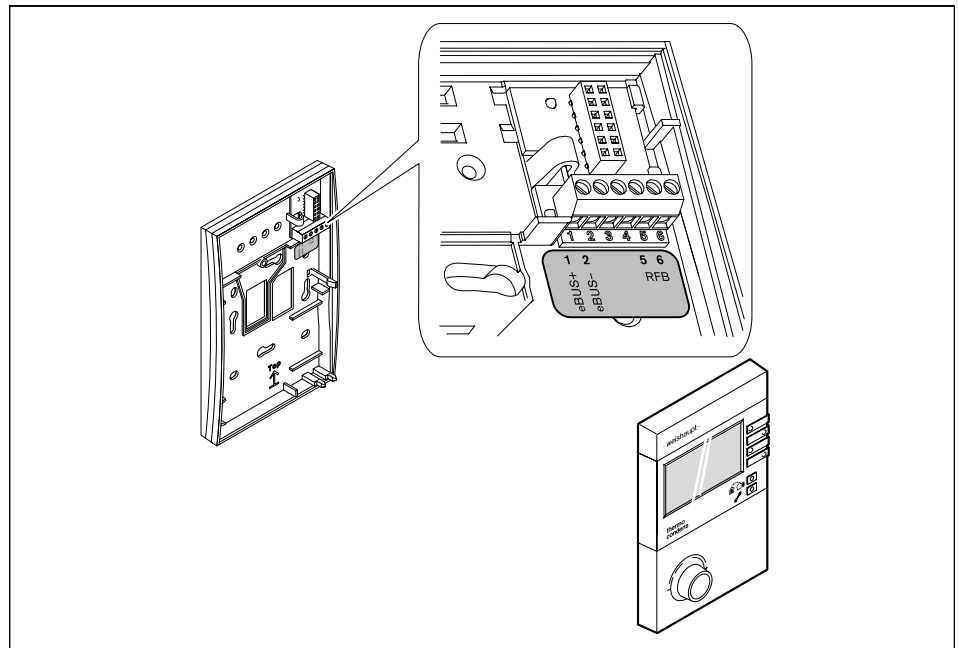

Generally, the use of screened electrical wiring is recommended.

## 5 Electrical installation

### 5.2 WCM-EM

#### 5.2.1 Open housing cover

- ▶ Lightly push down lug with screwdriver.
- ▶ Remove housing cover.

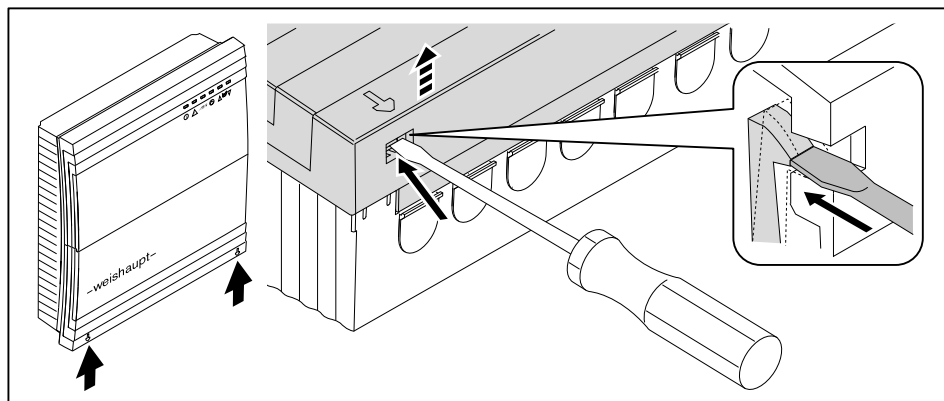

#### 5.2.2 Connect WCM-EM

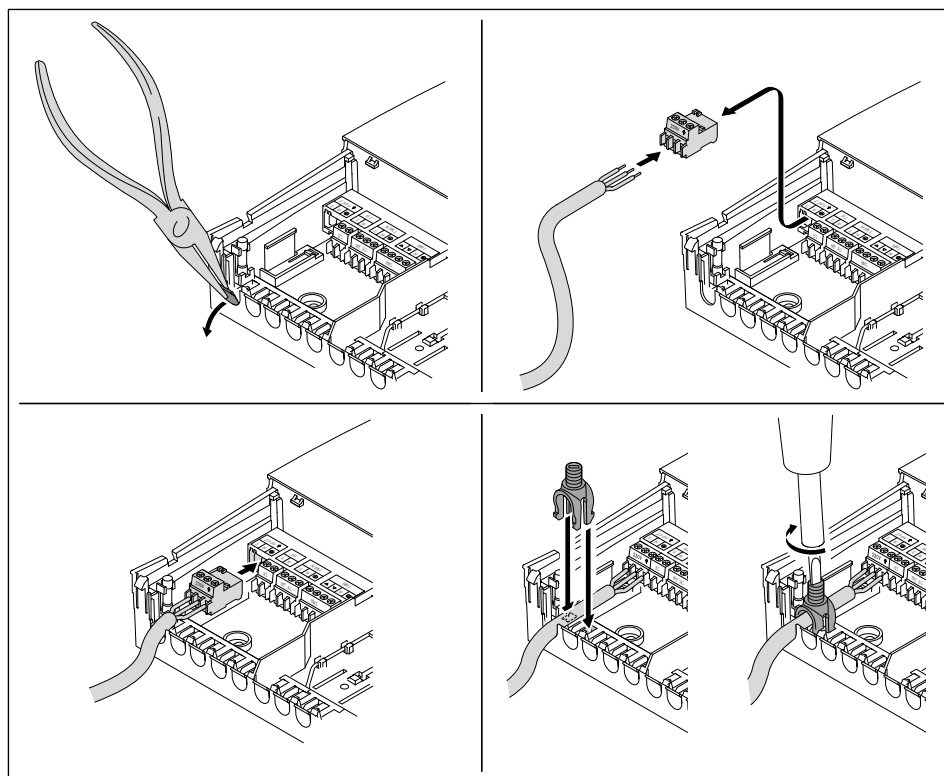

## 5 Electrical installation

### Screened cables

External sensor B1 and eBUS can be connected via the screen plate.

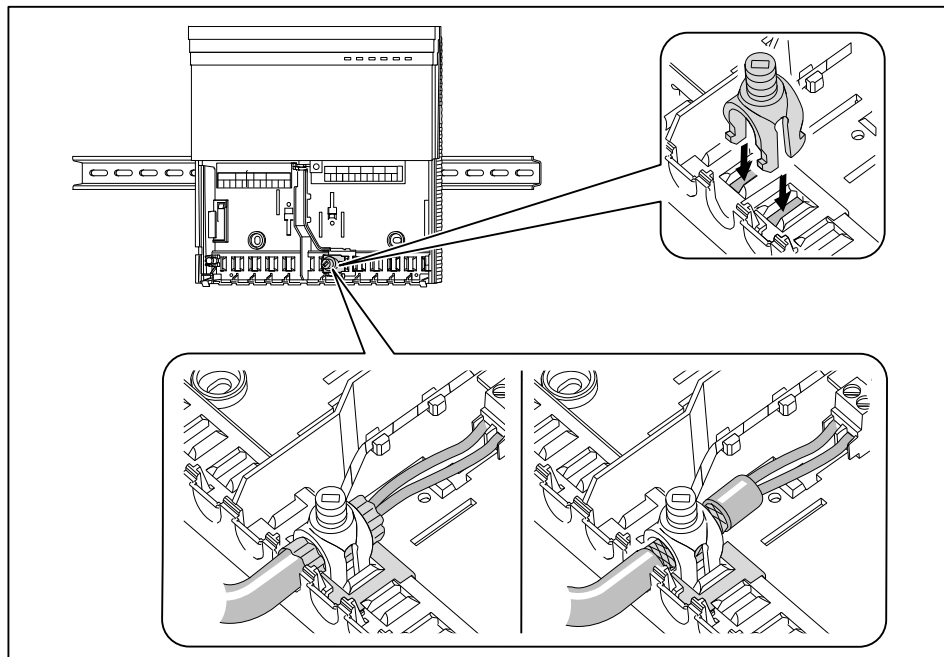

► Ensure correct polarity of the eBUS.



Generally, the use of screened electrical wiring is recommended.

## 5 Electrical installation

### 5.2.3 Connecting WCM-EM to condensing boiler

A maximum of 2 extension modules can be connected to terminal 2 of the condensing boiler.

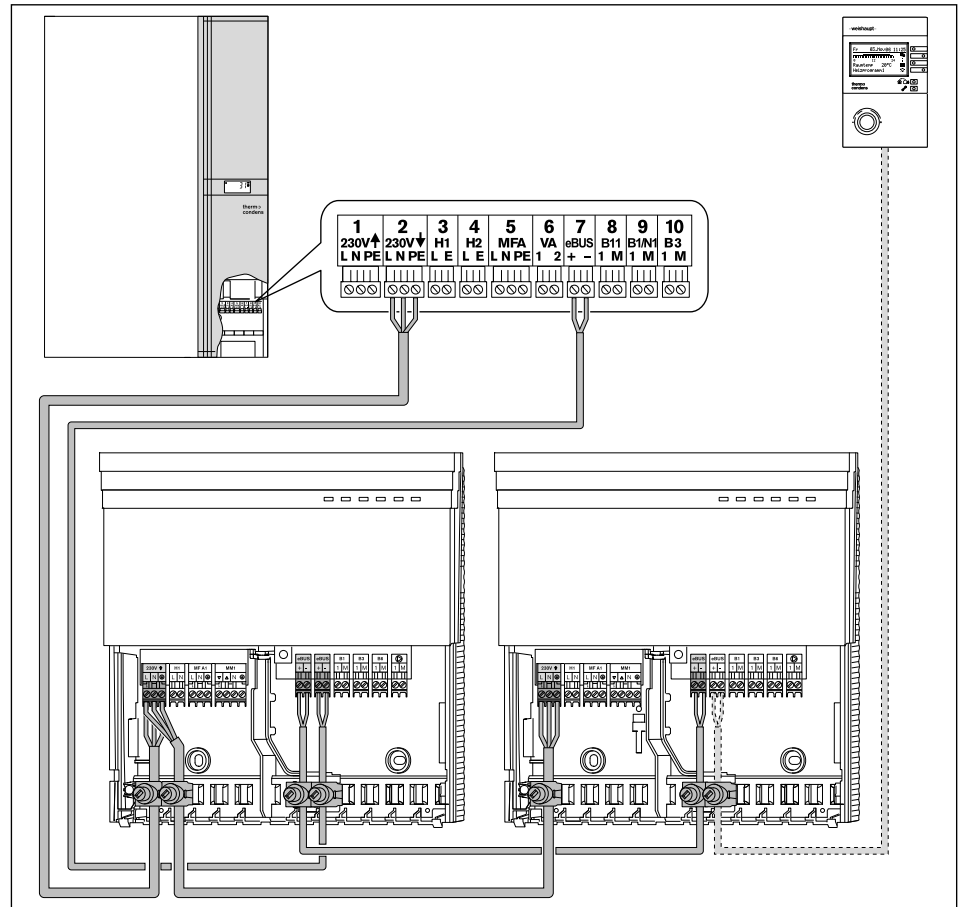

#### Several extension modules

If more than 2 extension modules are required:

- ▶ Connect condensing boiler and extension module via external main switch.

5 Electrical installation

5.2.4 Wiring diagram WCM-EM as heating circuit controller

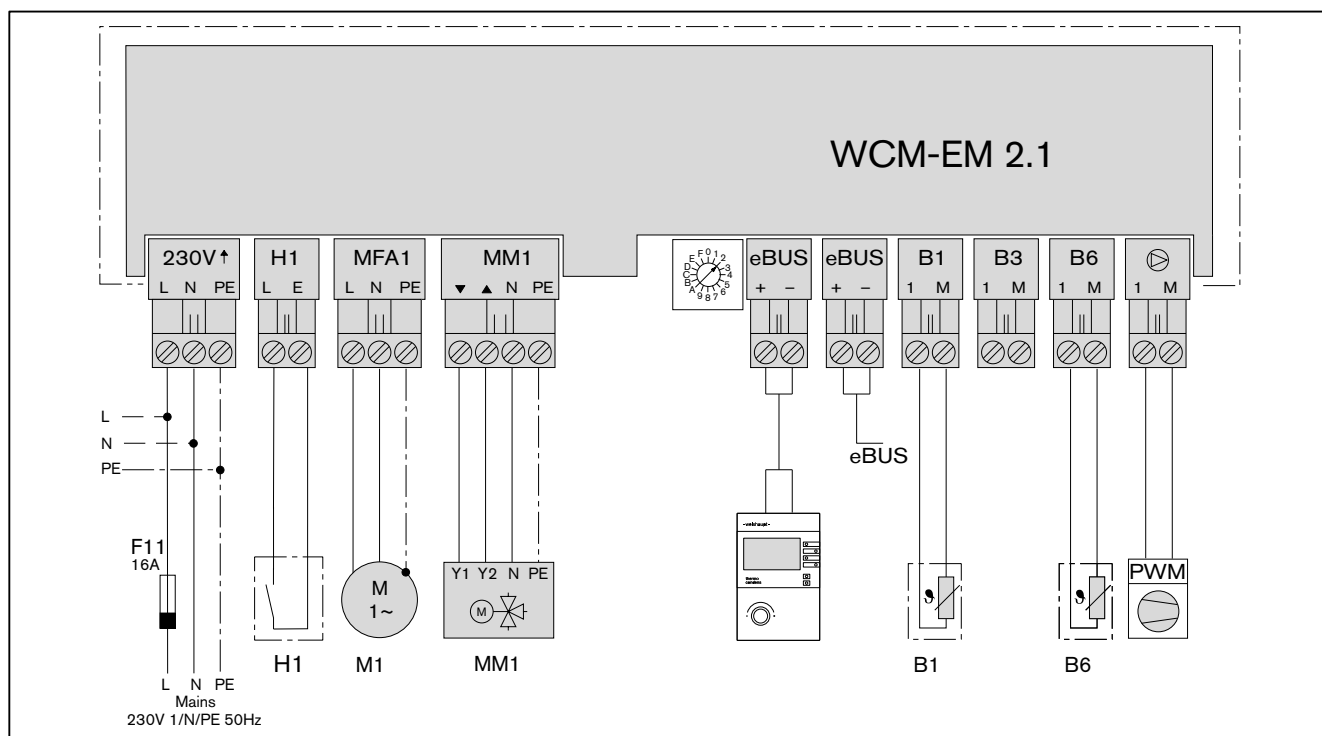

Plug	Colour	Connection	Remarks
230 V	black	Supply voltage 230 V AC/50 Hz	-
H1	turquoise	Variable input 230 V AC	Signal input with variable function
MFA 1	purple	Heating circuit pump	max. 5 A* **
MM1	yellow	Mixer motor	max. 5 A* **
eBUS	light blue	eBUS connection	-
B1	green	External sensor QAC 31 (NTC 600 Ω)	Weather compensation via separate external sensor for zone control
B6	white	Supply sensor NTC 5 kΩ	Heating circuit with separately controlled supply level via mixer
⊗	blue	PWM control	Modulation of heating circuit pump speed control

\* for electronic high efficiency pumps max 1.5 Ampere. Separate relay required for greater power consumptions.

\*\* Power consumption of outputs MFA 1 and MM1 in total maximal 5A.

5 Electrical installation

5.2.5 Wiring diagram WCM-EM as DHW load circuit

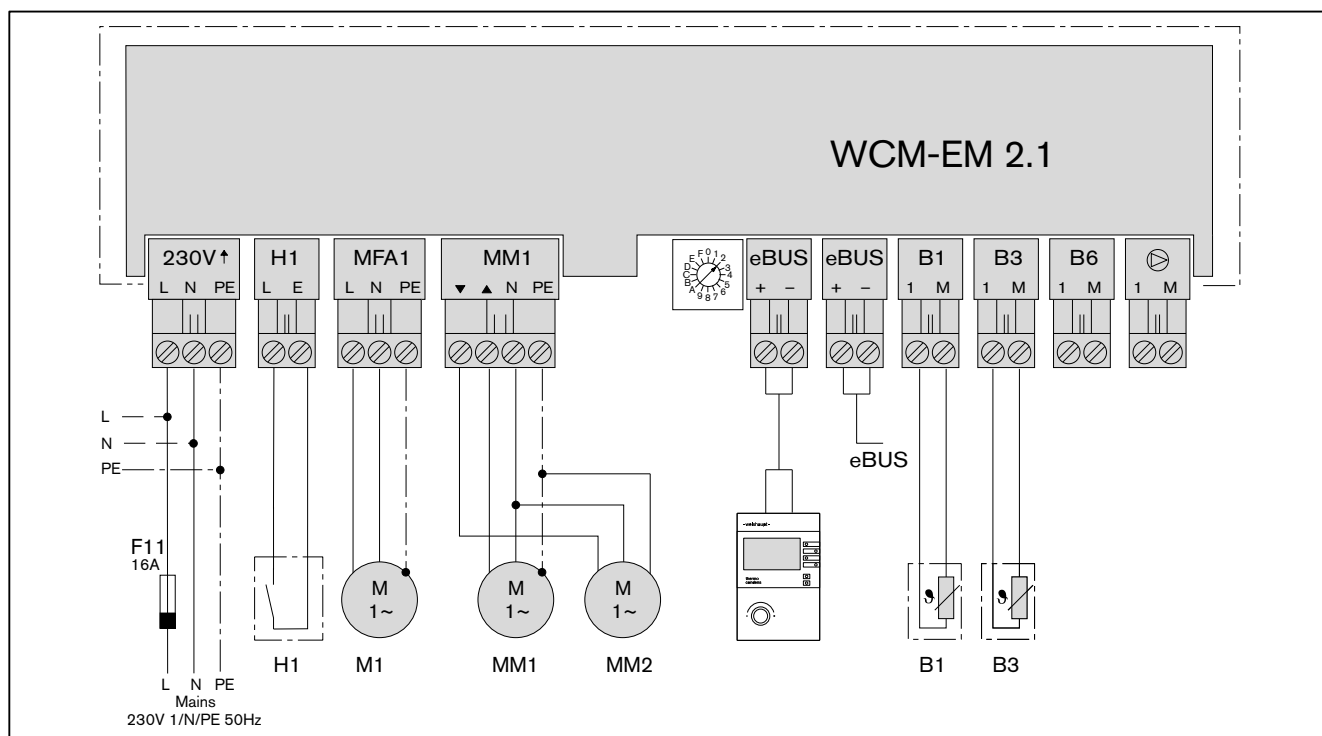

Plug	Colour	Connection	Remarks
230 V	black	Supply voltage 230 V AC/50 Hz	-
H1	turquoise	Variable input	Signal input with variable function
MFA 1	purple	Hot water load pump	max. 5 A* **
MM1	yellow	Circulation pump	max. 5 A* **
MM2	yellow	Antilegionella bypass pump	max. 5 A* **
eBUS	light blue	eBUS connection	-
B1	green	Circulation sensor NTC 5 kΩ	Additional circulation pump shut off when return temperature increases
B3	yellow	DHW sensor NTC 12 kΩ	WCM-EM acts as DHW load circuit

\* for electronic high efficiency pumps max 1.5 Ampere. Separate relay required for greater power consumptions.

\*\* Power consumption of outputs MFA 1 and MM1 in total maximal 5A.

5.2.6 Connecting the pump shut off set to the WCM-EM

A thermal shut off device must be fitted when using underfloor heating (accessory).

6 Operation

6 Operation

6.1 Operating panel WCM-FS 2.0

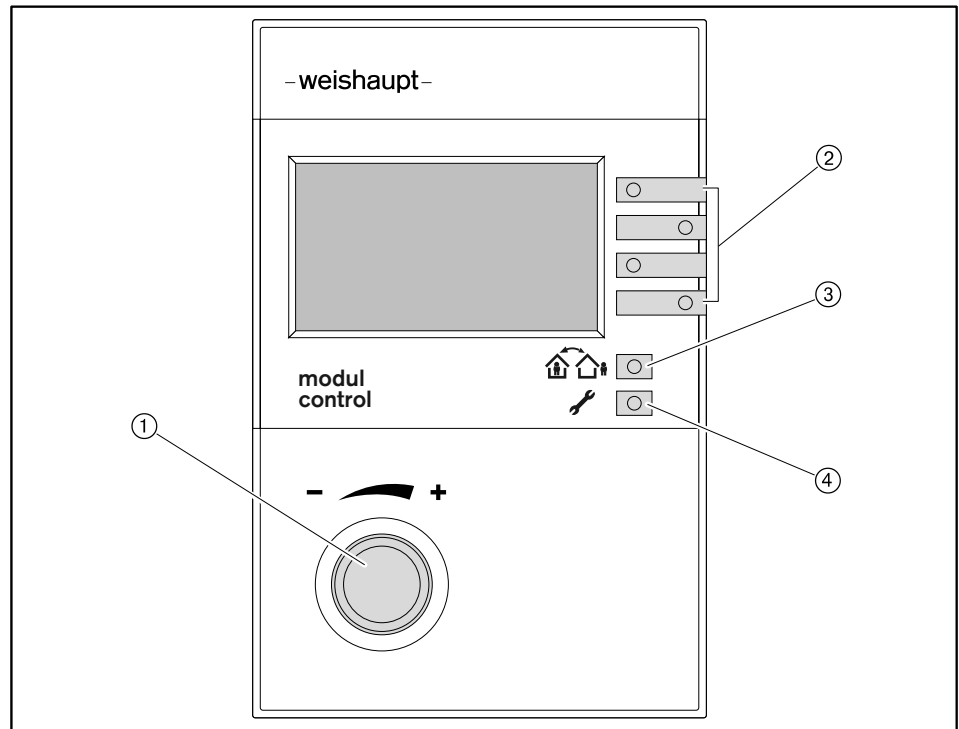

①	Dial knob	Navigation through levels and parameters, change values, switch on illumination.
②	Function keys 1 ... 4	Used to activate functions.
③	Presence and absence key	Used for short term interruption or extension of the heating program. Used to set duration of effectiveness.
④	Menu key	Used to activate or exit end user level. Used to access or exit heating engineer level.

## 6 Operation

### 6.2 Standard display



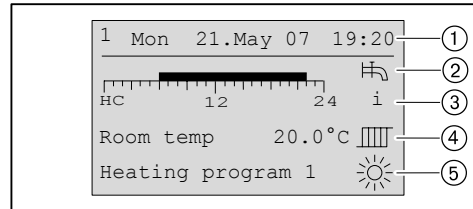

#### Factory presetting

Display of allocated factory pre-settings (standard).





- ① eBUS address, weekday, date, time
- ② Symbol DHW heating
- ③ Information  
Time bar, status, external temperature, DHW temperature
- ④ Current room temperature,  
if applicable current supply temperature
- ⑤ Type of operation with symbol

#### Symbols for type of operation

	Normal operation
	Night setback operation
	Summer (DHW operation only)
	Standby
A	Automatic adaption

6 Operation

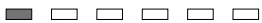
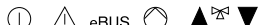
6.3 Operating display of the WCM-EM

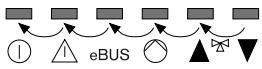
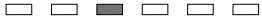
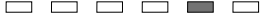
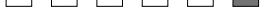
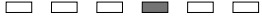
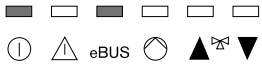
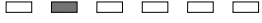
WCM-EM display	Display status	Meaning
 	Mains LED ON	Mains voltage applied
	Mains LED OFF	No mains voltage applied
	Mains LED flashing 50 % ON, 50 % OFF	Mains voltage applied, fault condition (e.g. sensor failure)
	All LED's flashing	eBUS address A set (see Ch. 7.1.1), after 10 seconds standard values are loaded (re- set)
	LED's turn on in sequence	Progress of loading process for standard values when resetting the WCM-EM (see Ch. 6.7)
	eBUS LED flashing 50 % ON, 50 % OFF	Start phase of unit
	eBUS LED flashes irregularly 5 % ON, 20 % OFF 5 % ON, 70 % OFF	Unit address is set correctly, Bus connection is made, Bus supply is correct
	eBUS LED continually OFF	BUS open circuit, no BUS connection or BUS is under-supplied
	eBUS LED continually ON	BUS is overloaded eBUS voltage > 100 mA
	eBUS LED flashing 50 % ON, 50 % OFF	Incorrect eBUS address set (see Ch. 7.1.1)
	Mixer Open LED ON	WCM-EM heating circuit Mixer motor in OPEN position
		WCM-EM DHW Control of circulation pump is active
	Mixer Closed LED ON	WCM-EM heating circuit Mixer motor drives closed
		WCM-EM-DHW Control of Antilegionella bypass pump active
	Pump LED ON	WCM-EM heating circuit Heating circuit pump in operation
		WCM-EM DHW DHW load pump in operation
	eBUS LED and Mains LED flashing	eBUS address F set (see Ch. 7.1.1), manual operation active
	Error LED flashes	Display of error via error code on WCM-FS (see Ch. 8.1).

## 6 Operation

### 6.4 End user level

#### Activate end user level

- ▶ Briefly press menu key   in the standard display.
- ✓ End user level is displayed.

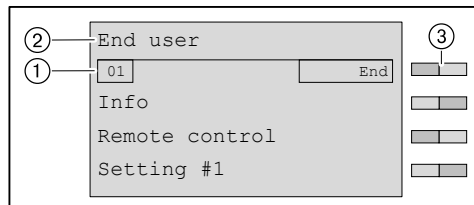

- ① Page number menu
- ② End user level
- ③ Function key for menu selection

#### Display further pages

- ▶ Turn the dial knob.
- ✓ Further pages of the menu are displayed.

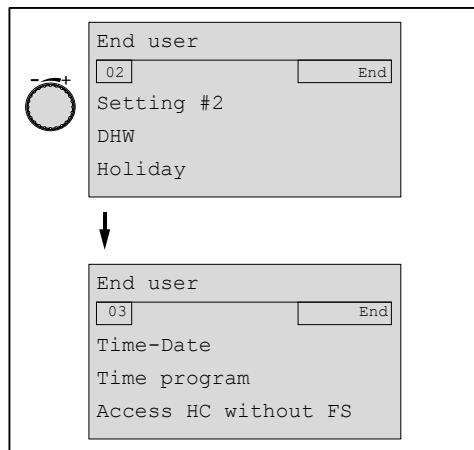

#### Selecting a menu

- ▶ Select menu and press the relevant function key.
- ✓ Menu is displayed.

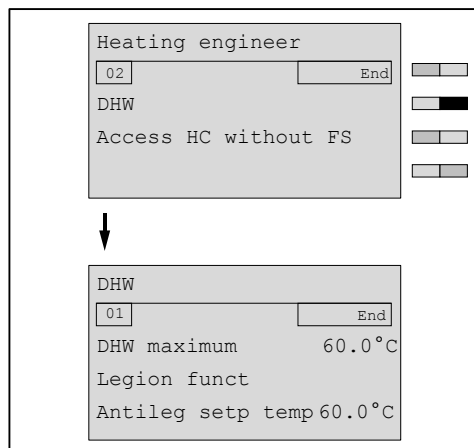

## 6 Operation

### Selecting and setting parameters

- ▶ Select parameter and press the relevant function key.
- ✓ Parameter is displayed.
- ▶ Make a selection using the dial knob and save setting with function key **OK**.

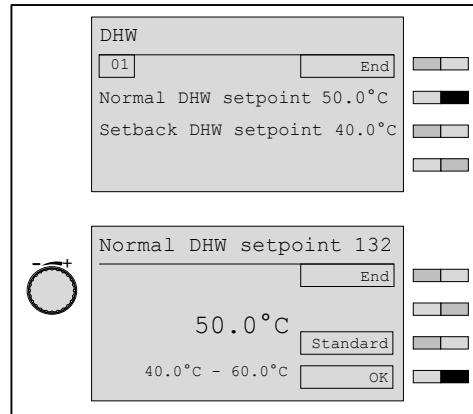

### Resetting parameters to factory presetting

- ▶ Press function key **Standard**.
- ✓ Factory presetting is displayed.
- ▶ Press function key **OK**.
- ✓ Factory presetting is saved.

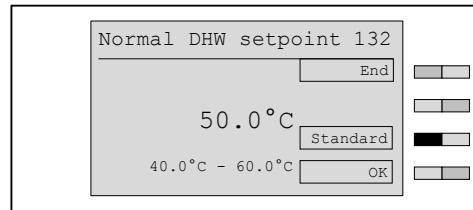

### Exit end user level

- ▶ Press function key **End** repeatedly – or – briefly press menu key.
- ✓ Standard display appears.

**6 Operation**

**6.4.1 Menu structure end user level**



Menu points and parameters are hidden or displayed according to the settings made in the heating engineer level and according to the module used for the system (e.g. several heating circuits).

Menu point	Parameters	Description	Factory pre-setting	Set
Info	01	External min	-	
	02	External max	-	
	03	Yield counter	-	
	04	Total yield	-	
	05	Statistic	-	
Remote control	P101	Room sensor corr	0.0K	
	P102	Contrast	04	
	P103	Illumination	30	
Settings#1	P111	Type of operation HC	-	
	P112	Normal room temp	21.5°C	
	P113	Setback room temp	16.0°C	
	P114	Acceptance room	Off	
	P115	Normal supply setpoint	75.0° C75.0°C	
	P116	Setback supply setpoint	45.0°C	
	P117	Gradient	10.0	
	P118	Room frost temp	10.0°C	
	P119	Su/Wi change	20.0°C	
Settings#2	P121	Normal supply setpoint#2	75.0°C	
	P122	Setback supply setpoint#2	45.0°C	
	P123	Gradient	-	
	P124	Su/Wi change	20.0°C	
DHW	P132	Normal DHW setpoint	50.0°C	
	P133	Setback DHW setpoint	40.0°C	
	P134	Acceptance DHW	Off	
Holiday	P141	Duration		
	P142	Temp level	Frost	
Time-Date	P151	Date	-	
	P152	Time	-	
	P153	Summertime start	25.March	
	P154	Summertime end	25.Oct	
Time program		Heating program 1	-	
		Heating program 2	-	
		Heating program 3	-	
	P161	Advance #2	10 min	
		DHW program	-	
		Circ. program	-	



**6 Operation**

Menu point	Parameters	Description	Factory pre-setting	Set
Access HC without FS		new config	-	
		List of all WCM-EM's without WCM-FS assigned EM-HK#2 or EM-WW#2 ... EM-HK#8 or EM-WW#8	-	

## 6 Operation

### 6.5 Heating engineer level

#### Activate heating engineer level

- ▶ Press and hold menu key   for 3 seconds.
- ✓ Heating engineer level is displayed.

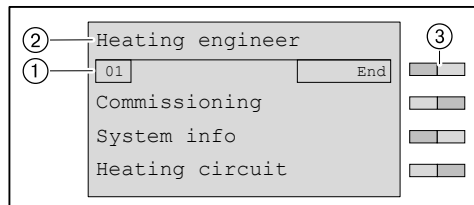

- ① Page number
- ② Heating engineer level
- ③ Function key for menu selection

#### Display further pages

- ▶ Turn the dial knob.
- ✓ Further pages of the menu are displayed.

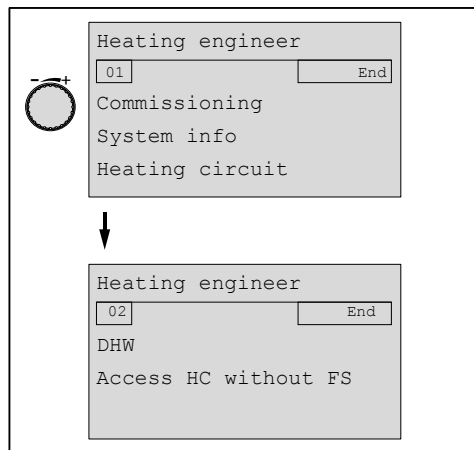

#### Selecting a menu

- ▶ Select menu and press the relevant function key.
- ✓ Menu is displayed.

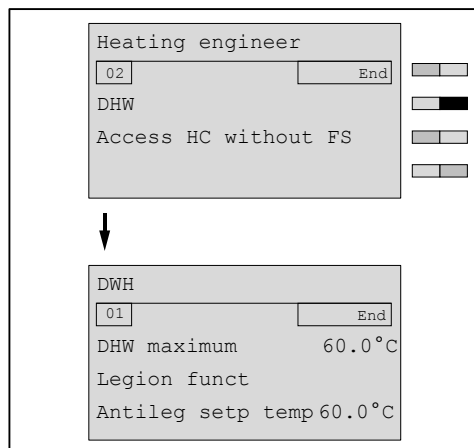

## 6 Operation

### Selecting and setting parameters

- ▶ Select parameter and press the relevant function key.
- ✓ Parameter is displayed.
- ▶ Make a selection using the dial knob and save setting with function key **OK**.

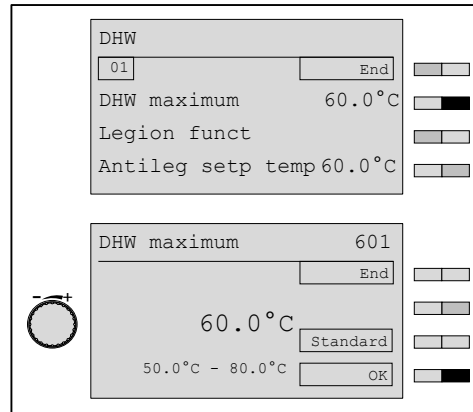

### Resetting parameters to factory presetting

- ▶ Press function key **Standard**.
- ✓ Factory presetting is displayed.
- ▶ Press function key **OK**.
- ✓ Factory presetting is saved.

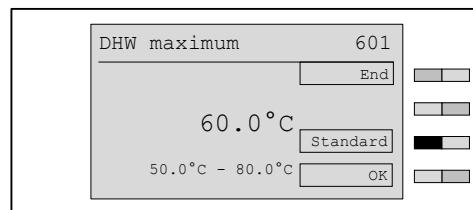

### Exit heating engineer level

- ▶ Press function key **End** repeatedly – or – briefly press menu key.
- ✓ Standard display appears.

**6 Operation**

**6.5.1 Menu structure heating engineer level**



Depending on the scope of the system some parameters may not be displayed

Menu point	Menu structure address		Factory pre-setting	Set	
	Parameter	Description			
Commissioning	P311	Language	German		
	P312	Address FS	-		
	P313	HC-Type#1 ... 8	Universal		
	P314	HC-Type#2	Universal		
	P315	Type of control#1 ... 8	External		
	P316	Type of control#2	External		
	P317	Sol diagram	WASol		
	P318	Application B3	CPU/KA		
	P319	Collector field	01		
	P320	Type WHPSol	20-7EA 1.0		
	P321	AP Max	-		
	P322	AP Min	-		
	System info	P331	External	current	°C
			dampened	°C	
			mixed	°C	
P332		Config WTC-X	-		
P333		Config Sol	-		
P334		Config user	-		
P335		Config FS	-		
P336		Config EM#X	-		
P337		Setpoint temp system	°C		
P338		Error history	-		
P339		Version WCM-FS	-		
P340	Version WCM-SOL	-			
P341	Version WCM-EM	-			

6 Operation

Menu point	Parameter	Description	Factory pre-setting	Set	
Heating circuit	Extension module#X	P401 H1-Fct HC	Standby		
		P403 Output test HC	-		
		P405 Correction external	0.0K		
	Setting#X	P421 Supply min	8°C		
		P422 Supply max	75°C		
		P423 DHW operation	Priority		
		P424 Boil-MC-boost	2K		
		P425 Mixer parameter	8K		
		P426 Frost protection	5°C		
		P427 Min. pump speed	50%		
		P428 Max. pump speed	100%		
		P429 Speed variable	Level		
		P430 Delay WTC	30secs		
		P431 SOL Yield HC	Off		
		Screed#X	P441 Screed	Off	
			P442 Screed day	-	
			P443 Start temp	25°C	
	P444 Days min temp Fht		3		
	P445 Max temp Fht		45°C		
	P446 Days max temp Fht		4		
	P447 Days cooling Fht		4		
	P448 Days heat-up Sht		3		
	P449 Max temp Sht		55°C		
	P450 Days max temp Sht		13		
	P451 Days cooling Sht	3			

6 Operation

Menu point	Parameter	Description	Factory pre-setting	Set
Heating circuit	Settings#2 (for WCM-FS#1+2)	P461 Supply min	8°C	
		P462 Supply max	75°C	
		P463 DHW operation	Priority	
		P464 Boil-MK boost	2K	
		P465 Mixer parameter	8K	
		P466 Frost protection	5°C	
		P467 Min. pump speed	50%	
		P468 Max. pump speed	100%	
		P469 Speed variable	Level	
		P470 Delay WTC	30s	
		P471 SOL yield HC	Off	
	Screed #2	P481 Screed	Off	
		P482 Screed day	-	
		P483 Start temp	25°C	
		P484 Day min temp Fht	3	
		P485 Max temp Fht	45°C	
		P486 Day max temp Fht	4	
		P487 Days cooling Fht	4	
		P488 Day heat-up Sht	3	
		P489 Max temp Sht	55°C	
P490 Days max temp Sht		13		
P491 Days cooling Sht	3			
Control behaviour	P501 Reduct	Setback		
	P502 Frost limit	Off		
	P503 On Opti	2h		
	P504 Construction	light		
	P505 Room ther#1	1 K		
	P506 Room ther#2	1 K		
	P507 Adaption#1	Off		
	P508 Room factor-P	5		

6 Operation

Menu point	Parameter	Description	Factory pre-setting	Set	
Heating circuit	Heating circuit info		P521 External EM-HC	°C	
			P522 Room temp	°C	
			P523 Supply#2	°C	
			P524 DHW	°C	
		P526 Set-points HC#1	Status	-	
			Setpoint temp	°C	
			Setpoint temp system	°C	
		P527 Set-points HC#2	Status	-	
			Setpoint temp	°C	
			Setpoint temp system	°C	
DHW	P601	DHW maximum		60°C	
	P605	Legio-Fct		Friday	
	P606	Antileg setpoint temp		60°C	
	P607	Legio time		20:00 hrs	
	P608	Circ with Legio		Off	
	P609	Circ time		3 min	
	P610	Circ temp		30°C	
	P611	SOL yield DHW		Off	
Solar	Inputs/outputs		P801 Output VA1	Lockout	
			P802 Output test	-	
	Buffer/de-couple		P821 Buffer switch diff	2K	
			P822 Buffer boost	1 K	
			P823 P2/P1 T-change	Off	
	Collector		P841 Min sup. flow	0.6l/min	
			P842 Max sup. flow	15l/min	
			P843 Collector Frost	-12°C	
			P844 Tyfocot	30%	
			P845 P min a collector	20W	
	DT controller		P861 Min collector	20°C	
			P862 Switch diff ON	7K	
			P863 Control differential	12K	
			P864 Switch diff OFF	4K	
	Energy management		P881 Sol excess	70°C	
			P882 Recooling	Off	
P883 Solar prio HC			Off		
P884 Solar prio DHW			Off		

6 Operation

Menu point	Parameter	Description	Factory pre-setting	Set	
Solar	Info Solar	P901 Buffer/de-couple	-		
		P902 Sta-tus DTR	Sol:	-	
			HC:	-	
			DHW:	-	
		P903 DTR tempera-tures	T1	°C	
			T2	°C	
		P904 WHP tempera-tures	T3	°C	
			T4	°C	
		P905 Col-lector circuit	P Pump	%	
			V	l/min	
			P th	kW	
		P906 Yield counter	from	Date	
			W th	kWh	
			Operation	h	
		P907 Total yield	W th	kWh	
			Operation	h	
P908 Sta-tistic	01	Date			
	W th	kWh			
	Operation	h			
Access HC without FS	New config List of all WCM-EM without WCM-FS assigned EM-HC#2 or EM-WW#2 ... EM-HC#8 or EM-WW#8				

6 Operation

6.5.2 Menu structure heating engineer level DHW



Depending on the scope of the system some parameters may not be displayed

Menu point	Parameters	Description	Factory pre-setting	Set	
Commissioning	P311	Language	German		
System info	P331	External	current	°C	
			dampened	°C	
			mixed	°C	
	P332	Config WTC-G		-	
	P334	Config user		-	
	P335	Config FS		-	
	P336	Config EM#X		-	
	P337	Setpoint temp system		°C	
	P338	Error history		-	
	P339	Version WCM-FS		-	
	P340	Version SOL		-	
P341	Version EM-DHW		-		
Heating circuit	Extension module #X	P402	H1-Fct DHW	Standby	
		P404	Output test DHW	-	
	Heating circuit info	P522	Room temp	°C	
		P524	DHW	°C	
		-	Circ temp	°C	
DHW	P601	DHW maximum		60°C	
	P602	DHW switch diff		-3.0K	
	P603	DHW boost		15K	
	P604	Max DHW load time		10 min	
	P605	Legio fct		Friday	
	P606	Antileg setpoint temp		60.0°C	
	P607	Legio time		22 hrs	
	P608	Circ during Legio		Off	
	P609	Circ time		3 min	
	P610	Circ temp		30.0°C	
	P611	SOL yield DHW		Off	
Access HC without FS					

**6 Operation**

**6.5.3 Menu structure heating engineer level control centre**



Depending on the scope of the system some parameters may not be displayed

Menu point	Parameter	Description	Factory pre-setting	Set	
Commissioning	P311	Language	German		
	P317	Sol diagram	WASol		
	P318	Application B3	CPU		
	P319	Number of collectors	01		
	P320	Type WHPSol	20-7EA 1.0		
	P321	AP Max	-		
	P322	AP Min	-		
System info	P331	External	current	°C	
			dampened	°C	
			mixed	°C	
	P332	Config WTC-X	-		
	P333	Config Sol	-		
	P334	Config user	-		
	P335	Config FS	-		
	P337	Setpoint temp system	°C		
	P338	Error history	-		
	P339	Version WCM-FS	-		
P340	Version WCM-SOL	-			
Heating circuit	Heating circuit info	P522 Room temp	°C		
		P524 DHW	°C		
		P526 Set-points HC#1	Status	-	
			Setpoint temp	-	
	Setpoint temp system	-			
DHW	P601	DHW maximum	60°C		
	P605	Legio-Fct	Friday		
	P606	Antileg setpoint temp	60°C		
	P607	Legio time	22:00 hrs		
	P608	Circ with Legio	Off		
	P609	Circ time	3 min		
	P611	SOL yield DHW	Off		

6 Operation

Menu point	Parameter	Description	Factory pre-setting	Set	
Solar	Inputs/outputs	P801 Output VA1	Lockout		
		P802 Output test	-		
	Buffer/de-couple	P821 Buffer switch diff	2K		
		P822 Buffer boost	1 K		
		P823 P2/P1 T-change	Off		
	Collector	P841 Min sup. flow	0.6l/min		
		P842 Max sup. flow	15l/min		
		P843 Collector Frost	-12°C		
		P844 Tyfocot	30%		
		P845 P min a collector	20W		
	DT controller	P861 Min collector	20°C		
		P862 Switch diff ON	7K		
		P863 Control differential	12K		
		P864 Switch diff OFF	4K		
	Energy management	P881 Sol excess	70°C		
		P882 Recooling	Off		
		P883 Prio Solar HC	Off		
		P884 Prio Solar DHW	Off		
	Info Solar	P901 Buffer/de-couple	B10	°C	
			B11	°C	
			P2->P1	Off	
		P902 Status DTR	Sol:	-	
			HC:	-	
			DHW:	-	
		P903 DTR temperatures	T1	°C	
			T2	°C	
		P904 WHP temperatures	T3	°C	
			T4	°C	
		P905 Collector circuit	P	%	
			V	l/min	
			P th	kW	
		P906 Yield counter	from	Date	
			W th	kWh	
			Operation	h	
		P907 Total yield	W th	kWh	
			Operation	h	
P908 Statistic		01	Date		
		W th	kWh		
	Operation	h			
Access HC without FS	New config List of all WCM-EM without WCM-FS assigned				

## 6 Operation

### 6.5.4 Setting the language

#### Languages

Deutsch  
English  
Français  
Italiano  
Español  
Nederlands  
Dansk  
Svenska  
Norsk  
Slovenski  
Hrvatski  
Magyar  
Polski  
Русский  
Česky  
Slovak

- ▶ Activate heating engineer level (see Ch. 6.5).
- ▶ Press function key Commissioning.
- ✓ Menu Commissioning is displayed.
- ▶ Press function key Language.
- ✓ Parameter Language is displayed.
- ▶ Set language using the dial knob and save with function key OK.

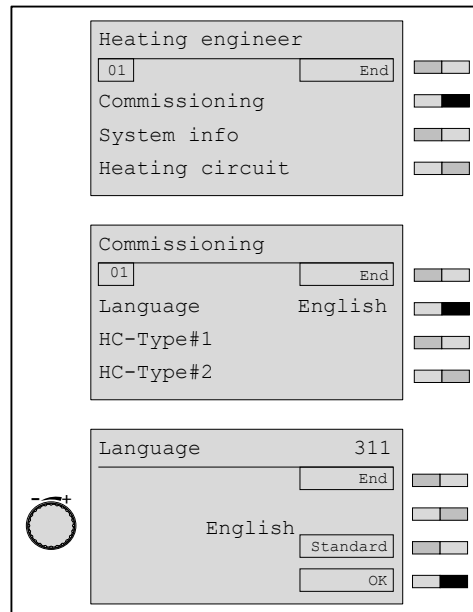

**6 Operation**

**6.5.5 Configuration of the WTC heat exchanger**

This parameter is used to transfer the configuration information from the condensing boiler to the WCM-FS.

Heat exchanger	Config WTC ... #1	Unit type, load and eBUS address of the heat exchanger
Hydraulic version	DHW	WTC, vers. -W (water heater) sensor B3 installed in the unit
	Heating appliance	WTC, vers. -H
	Combi	WTC, vers. -C DHW preparation via plate heat exchanger
	Integra	WTC, vers. -K with WAI
	Power	WTC, vers. -K with WAP
External sensor	External sensor	External sensor B1 installed
Control variation	Buffer 1	Buffer control with sensor B10
	Buffer 2	Buffer control with 2 sensors B10 + B11
	De-couple	De-couple control with sensor B11

- ▶ Activate heating engineer level (see Ch. 6.5).
- ▶ Press function key `System info`.
- ✓ Menu `System info` is displayed.
- ▶ Press function key `Config WTC-G ...#1` and, where applicable, `Config WTC-O ...#1`.
- ✓ Parameter `Config WTC-G ...#1` and, where applicable, `Config WTC-O ...#1` is displayed.
- ▶ Check, if configuration WCM-FS and WTC are the same (WTC parameter 10 heating engineer level).
- ▶ If the configuration is not the same, press function key `New`.
- ✓ The message `search config` appears briefly, then the current configuration is displayed.
- ▶ Exit menu using function key `End`.

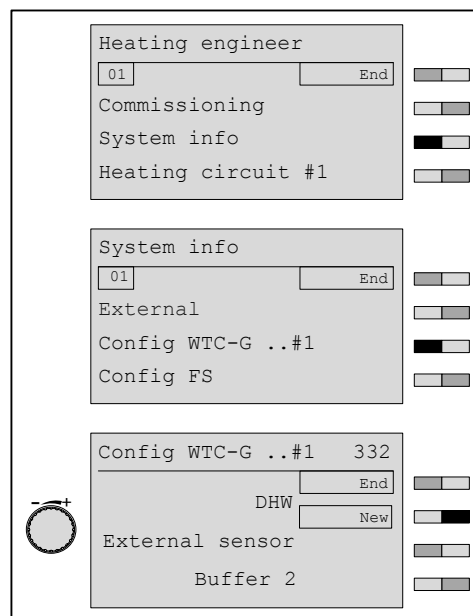

**6 Operation**

**6.5.6 Configuration WCM-EM**

This parameter is used to transfer the configuration information from the WCM-EM to the WCM-FS.

Unit	Config EM#2	Extension module #2
Heating circuit/DHW	HC pump	Pump heating circuit no separate supply sensor connected
	HC mixer	Mixer heating circuit separate supply sensor B6 connected
	DHW	DHW load circuit DHW sensor B3 connected
Pump	PWM pump	Version
	stage pump	PWM input connected or not connected
External sensor	External sensor	Separate external sensor for zone control connected
Circulation sensor	Circ ret sensor	Circulation sensor B1 connected for shut off of circulation pump
eBUS supply	Auto Volt On	Information about the status of the eBUS supply
	Auto Volt Off	

- ▶ Activate heating engineer level (see Ch. 6.5).
- ▶ Press function key *System info*.
- ✓ Menu *System info* is displayed.
- ▶ Use dial knob to move to the second menu level.
- ▶ Press function key *Config EM#2*.
- ✓ Parameter *Config EM#2* is displayed.
- ▶ Check configuration displayed.
- ▶ If the configuration is not the same, press function key *New*.
- ✓ The message *search config* appears briefly, then the current configuration is displayed.
- ▶ Save new configuration with *OK*.

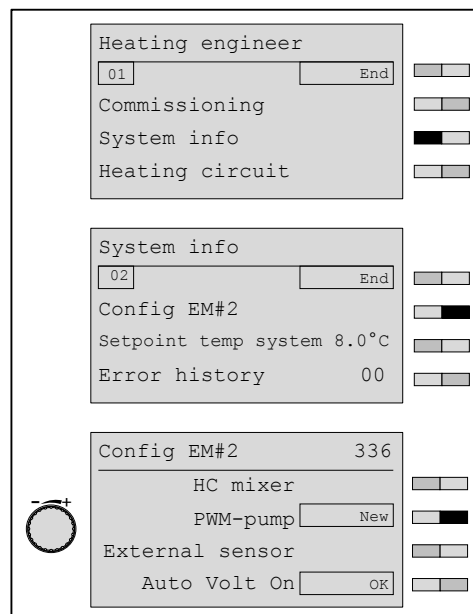

**6 Operation**

**6.5.7 Set heating circuit type#1 ... 8**

A heating circuit type must be set for each heating circuit.

Depending on the heating circuit type set the following will be carried out automatically:

- defined reduction of the value range,
- Parameter preconfigured with factory settings.

**Setting range**

FBH-heat-up	Floor warming
FBH-heating	Underfloor heating
Radiator 60	Low temperature layout of radiators
Radiator 70	Normal layout of radiators
Convector	Convectors
Universal	All controller settings possible.

Settings heating circuit type Parameter 316/317		Floor warming	Underfloor heating	Radiator 60 °C	Radiator 70 °C	Convector heating	Universal
Normal sup set <sup>(1)</sup> Parameter 114/ 121 <sup>(2)</sup>	Factory presetting	25 °C	35 °C	60 °C	75 °C		
Setback sup1 set <sup>(1)</sup> Parameter 115/122 <sup>(2)</sup>	Factory presetting	16 °C	20 °C	35 °C	40 °C	45 °C	
Gradient Parameter 116/123 <sup>(2)</sup>	Range of values	2.5 - 6	4 - 10	8 - 20	11 - 25	11 - 40	2.5 - 40
	Factory presetting	2.5	5	10	12.5	12.5	10
Supply max Parameter 342/362 <sup>(3)</sup>	Range of values	Parameter 341 ... 50 °C Parameter 361 ... 50 °C		Parameter 341 ... 75 °C Parameter 361 ... 75 °C		Parameter 341 ... 80 °C Parameter 361 ... 80 °C	Parameter 342 ... 82 °C Parameter 362 ... 82 °C
	Factory presetting	30 °C	40 °C	65 °C	75 °C		
On Opti Parameter 383 <sup>(3)</sup>	Factory presetting (actual value)	1:15		00:45		00:30	2:00
Pre-setting HC#2	Factory presetting	60		20		10	Off
Room thermostat Parameter 388/389 <sup>(3)</sup>	Factory presetting	Day Off		1 K			

<sup>(1)</sup> Parameter only available with heating circuit setting control type Const sup.

<sup>(2)</sup> User level.

<sup>(3)</sup> Heating engineer level.

### 6 Operation

- ▶ Activate heating engineer level (see Ch. 6.5).
- ▶ Press function key *Commissioning*.
- ✓ Menu *Commissioning* is displayed.
- ▶ Press function key *HC type#1*.
- ✓ Parameter *HC type#1* is displayed.
- ▶ Make selection using the dial knob and save with function key *OK*.

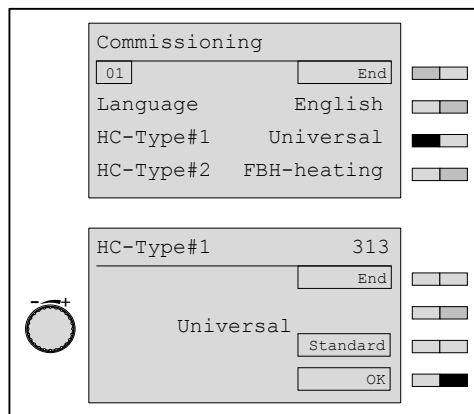

#### Set heating circuit type at address WTC-HC#1+EM-HC#2

If address WTC-HC#1+EM-HC#2 (living quarters heated with 2 heating circuits) is set, menu *Commissioning* also displays parameter *HC type#2* for the extended heating circuit. The setting is made as described for *HC type#1*.

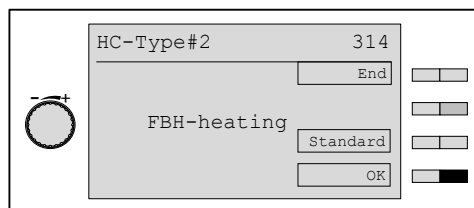

**6 Operation**

**6.5.8 Set control variable#1 ... 8**

Setting	Control	Active sensor
Const supl	Constant heating circuit control to the normal and setback supply setpoints set. Room frost protection and optimisation function are not active. The heating circuit pump is operated continuously except in Standby operation.	-
External	External temperature dependent control. The supply temperature varies depending on the external temperature.	External sensor
Room	Room temperature dependent control. The supply temperature of the heating circuit is determined using the deviation of actual room temperature from setpoint room temperature. Room frost protection is active.	Room sensor
External/ Room	Combination of weather compensated and room temperature dependent control.	External sensor/room sensor

- ▶ Activate heating engineer level (see Ch. 6.5).
- ▶ Press function key *Commissioning*.
- ✓ Menu *Commissioning* is displayed.
- ▶ Use dial knob to move to the second menu level.
- ▶ Press function key *Type of control#1*.
- ✓ Parameter *Type of control#1* is displayed.
- ▶ Make selection using the dial knob and save with function key *OK*.

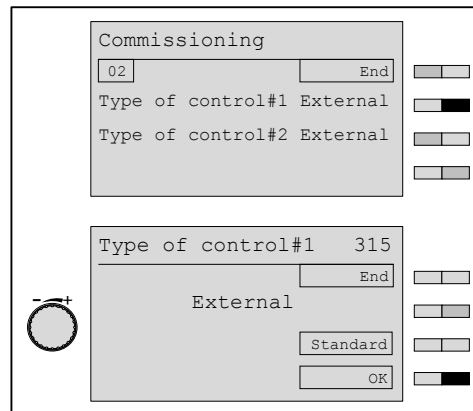

**Set type of control at address WTC-HC#1+EM-HC#2 (see Ch. 7.2.2)**

If address WTC-HC#1+EM-HC#2 is set, menu *Commissioning* also displays parameter *Type of control#2* for the extended heating circuit. The setting is made as described for type of control#1 ... 8.

**Setting range**

Const supl	Constant heating circuit control to the normal and setback supply setpoints set. Suitable for process plant with constant supply temperature.
External	With external sensor fitted.

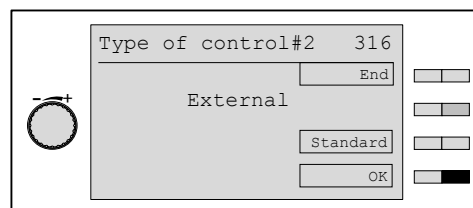

## 6 Operation

### 6.5.9 Retrieving system information

#### Parameters

External	Current external temperature
current	Calculation factor of weather compensation
damped	Weather compensation influenced by the type of construction of the building
mixed	
Config WTC	Information configuration of WTC
Config Sol	Information configuration WCM-SOL 1.0 home
Config user	Information configuration of heating and DHW load circuits connected
Config FS	Information configuration of WCM-FS
Config EM	Information configuration of WCM-EM
Setpoint temp system	Information about current system setpoint temperature
Error history	Entries of the last 10 errors or rectified errors with error source, error code, date and time.
Version WCM-FS	Software version of WCM-FS
Version WTC	Software version of WTC
Version EM-HC	Software version of WCM-EM

- ▶ Activate heating engineer level (see Ch. 6.5).
- ▶ Press function key `System info`.
- ✓ Menu `System info` is displayed
- ▶ Press function key `External`.
- ✓ Parameter `External` is displayed.
- ▶ Exit parameter using function key `End`.

Retrieve the following parameter as described above.

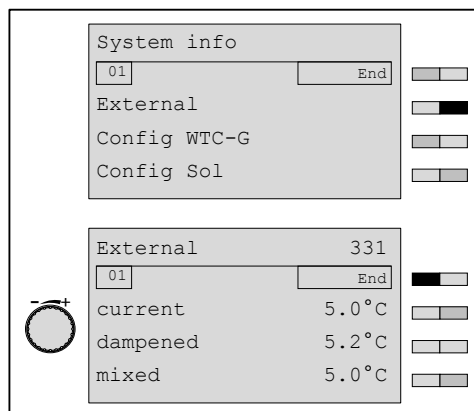

## 6 Operation

### Error history

Error messages from the eBUS participants are only displayed if they last longer than 15 minutes. Up to 10 error messages or rectified errors are stored in the error history of the WCM-FS with error source, error code, date and time. If the error messages ceases, this is stored in the error history with error code 00.

The error history can be reset using function key *Reset*.

### Example

An error was stored in the error history at 14:32 hrs. on the 04. January 2006. The fault was rectified 5 minutes later and was stored in the error history as a rectified error at 14:37 hrs.

Error entry 01 shows:

- Rectified error with source of error WTC-G#1,
- Error code 00,
- Date 04. Jan 06,
- Time 14:37.

Error entry 02 shows:

- Error with source of error WTC-G#1,
- Error code 15,
- Date 04. Jan 06,
- Time 14:32.

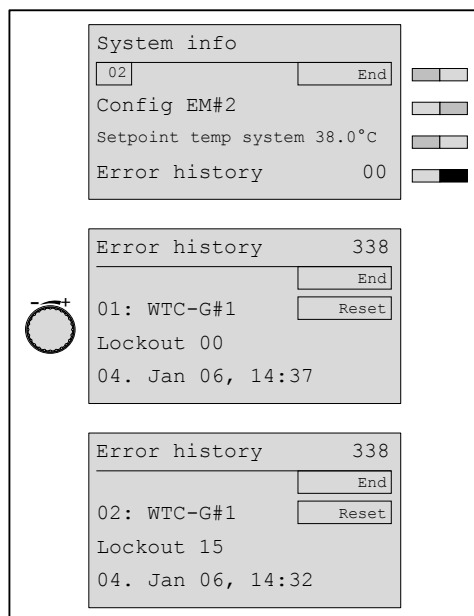

6 Operation

6.5.10 Set function of variable input H1



The settings described below are in each case activated with closed contact!

Setting range extension module heating circuit

Standby	Heating operation is prevented. Frost protection remains activated.
Normal	Constant heating operation, setback phase is prevented.
Setback	Constant setback operation, normal heating phase is prevented.

Setting range extension module DHW

Standby	No DHW operation, circulation pump off, Legionella function remains activated.
HE interlock	Blocks the heat exchanger for DHW operation.
Circ pump	Manually activated operation of the circulation pump. The circulation pump starts when the contact is closed. Once the contact is reopened, the pump runs on for the duration set in P609 (pulse mode).

- ▶ Activate heating engineer level (see Ch. 6.5).
- ▶ Press function key Heating circuit.
- ▶ Press function key Extension module #2.
- ✓ Menu Extension module #2 is displayed.
- ▶ Press function key H1-Fct HC and, where applicable, H1-Fct DHW.
- ✓ Parameter H1-Fct HC and, where applicable, H1-Fct DHW is displayed.
- ▶ Make selection using the dial knob and save with function key OK.

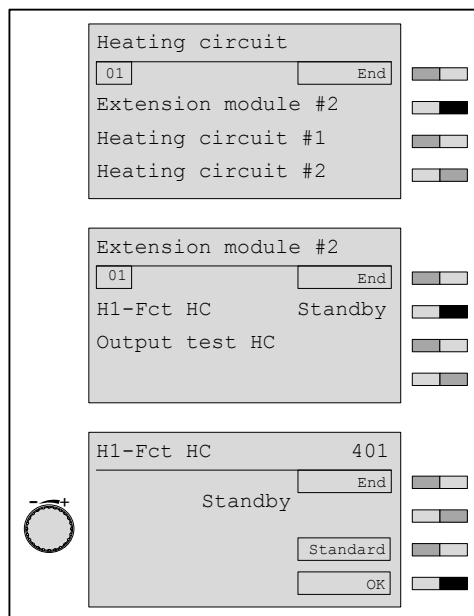

## 6 Operation

### 6.5.11 Test heating circuit/DHW outputs

Using parameter Output test, the actuators connected to the WCM-EM can be switched manually for test purposes.

#### Setting range extension module heating circuit

Pump On/Pump Off  
Mixer Open/Mixer Closed

#### Setting range extension module DHW

DHW pump On/DHW pump Off  
Circ pump On/Circ pump Off

- ▶ Activate heating engineer level (see Ch. 6.5).
- ▶ Press function key Heating circuit.
- ▶ Press function key Extension module #2.
- ✓ Menu Extension module #2 is displayed.
- ▶ Press function key Output test HC and, where applicable, Output test DHW.
- ✓ Parameter Output test HC and, where applicable, Output test DHW is displayed.
- ▶ Using the function keys set the pump and mixer and, where applicable, the DHW and circulation pumps.

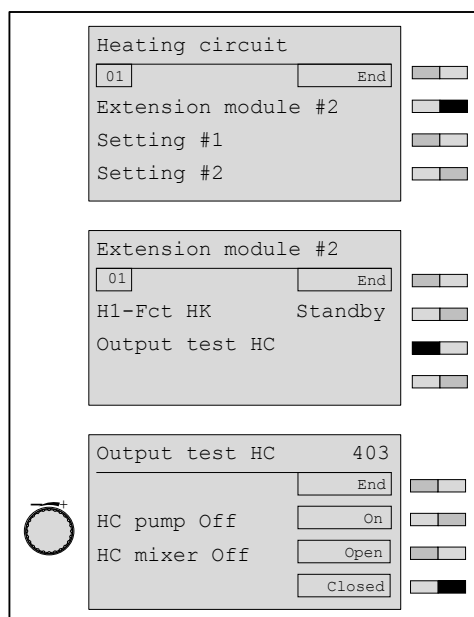

6 Operation

6.5.12 Set external sensor correction on WCM-EM



This parameter is only displayed, if a separate external sensor has been connected to the connection of the WCM-EM B1 (zone control).

Sensor tolerances can be adjusted with this parameter.

- ▶ Activate heating engineer level (see Ch. 6.5).
- ▶ Press function key Heating circuit.
- ▶ Press function key Extension module #2.
- ✓ Menu Extension module #2 is displayed.
- ▶ Press function key Correct external sensor.
- ✓ Parameter Correct external sensor is displayed.
- ▶ Set value using the dial knob and save with function key OK.

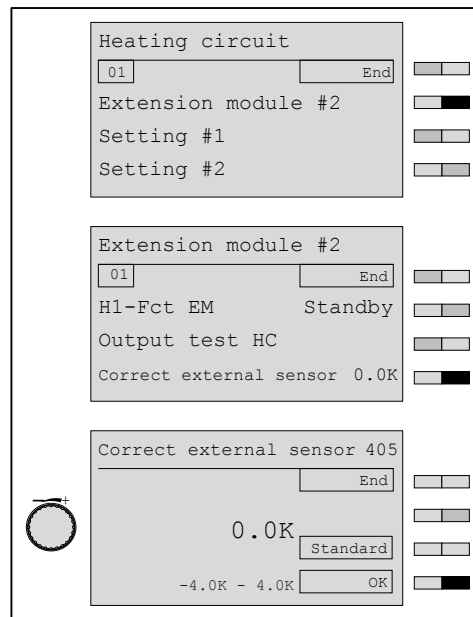

## 6 Operation

### 6.5.13 Set minimum supply temperature

This parameter is used to limit the supply setpoint downwards.

- ▶ Activate heating engineer level (see Ch. 6.5).
- ▶ Press function key Heating circuit.
- ▶ Press function key Setting #2.
- ✓ Menu Setting #2 is displayed.
- ▶ Press function key Supply min.
- ✓ Parameter Supply min is displayed.
- ▶ Set value using the dial knob and save with function key OK.

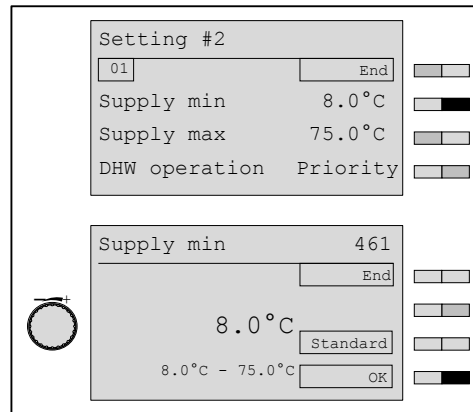

## 6 Operation

### 6.5.14 Set maximum supply temperature

This parameter limits the heat demand to the maximum supply temperature.

- ▶ Activate heating engineer level (see Ch. 6.5).
- ▶ Press function key Heating circuit.
- ▶ Press function key Setting #2.
- ✓ Menu Setting #2 is displayed.
- ▶ Press function key Supply max.
- ✓ Parameter Supply max is displayed.
- ▶ Set value using the dial knob and save with function key OK.

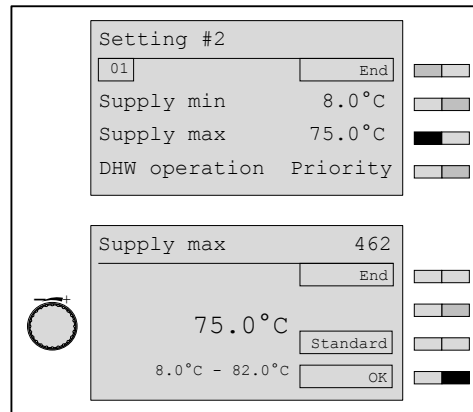

6 Operation

6.5.15 Set priority of DHW loading



The direct heating circuit (WCM-FS#1) is always operated with setting "Priority". In this case the parameter is faded out.

Setting range

Priority	DHW has priority. The heating circuit is blocked for the duration of DHW operation.
Parallel	DHW and heating circuit are supplied in parallel.
Sliding	If the boiler temperature falls below the actual DHW value by +10 K, the heat consumption of the heating circuits is switched off. If the boiler temperature exceeds the actual DHW value by +20 K DHW and heating circuits are again supplied in parallel.

- ▶ Activate heating engineer level (see Ch. 6.5).
- ▶ Press function key Heating circuit.
- ▶ Press function key Setting #2.
- ✓ Menu Setting #2 is displayed.
- ▶ Press function key DHW operation.
- ✓ Parameter DHW operation is displayed.
- ▶ Make selection using the dial knob and save with function key OK.

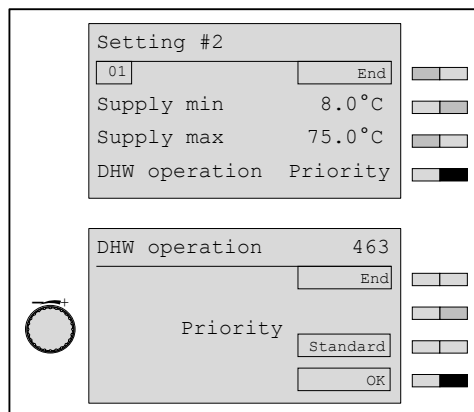

6 Operation

6.5.16 Set boiler mixer circuit boost



Only on heating circuit with mixer (supply sensor B6 fitted to WCM-EM).

This parameter is used to adjust ratings losses. If the mixer circuit boost is too great this will have a detrimental effect on the benefits of condensing technology.

- ▶ Activate heating engineer level (see Ch. 6.5).
- ▶ Press function key Heating circuit.
- ▶ Press function key Setting #2.
- ✓ Menu Setting #2 is displayed.
- ▶ Press function key Boil.MC boost.
- ✓ Parameter Boil.MC boost is displayed.
- ▶ Set value using the dial knob and save with function key OK.

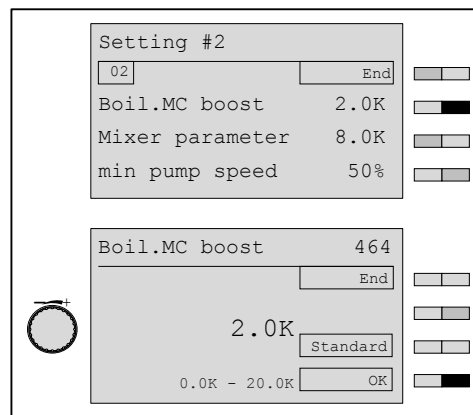

6 Operation

6.5.17 Set mixer parameters



Only on heating circuit with mixer (supply sensor B6 fitted to WCM-EM).

This parameter is used to match the WCM-EM to the mixer.

The value (temperature in K) defines the regulating range within which the signal is given in linear impulses. In addition the control impulse is "Continually open" or "Continually closed".

- ▶ Activate heating engineer level (see Ch. 6.5).
- ▶ Press function key Heating circuit.
- ▶ Press function key Setting #2.
- ✓ Menu Setting #2 is displayed.
- ▶ Press function key Mixer parameter.
- ✓ Parameter Mixer parameter is displayed.
- ▶ Set value using the dial knob and save with function key OK.

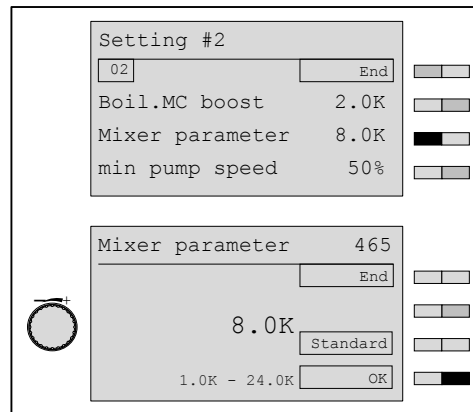

## 6 Operation

### 6.5.18 Set frost protection



This parameter is only displayed if a separate external sensor has been connected to connection B1 (zone control).

Heating circuit pump On current external temperature < parameter 426 - 5 K  
current external temperature < parameter 466 - 5 K (HC #1 +2)

Heating circuit pump Off current external temperature > parameter 426  
current external temperature > parameter 466 (HC #1+2)

- ▶ Activate heating engineer level (see Ch. 6.5).
- ▶ Press function key Heating circuit.
- ▶ Press function key Setting #2.
- ✓ Menu Setting #2 is displayed.
- ▶ Press function key Frost protection.
- ✓ Parameter Frost protection is displayed.
- ▶ Set value using the dial knob and save with function key OK.

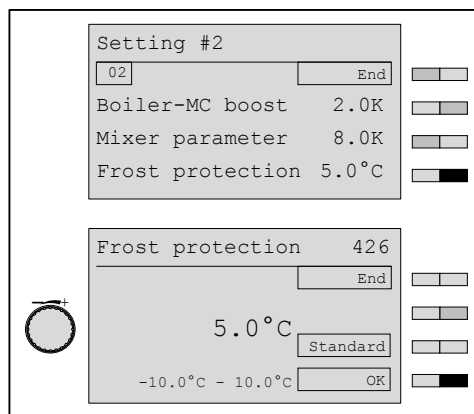

6 Operation

6.5.19 Set minimum pump speed



Parameter is only displayed if a PWM pump is connected

This parameter is used to set the lower operating point of the PWM pump (minimum load).

- ▶ Activate heating engineer level (see Ch. 6.5).
- ▶ Press function key Heating circuit.
- ▶ Press function key Setting #2.
- ✓ Menu Setting #2 is displayed.
- ▶ Press function key min pump speed.
- ✓ Parameter min pump speed is displayed.
- ▶ Set value using the dial knob and save with function key OK.

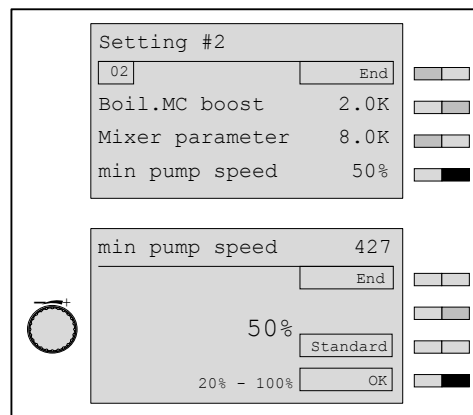

6 Operation

6.5.20 Set maximum pump speed



Parameter is only displayed if a PWM pump is connected

This parameter is used to set the upper operating point of the PWM pump (maximum load).

- ▶ Activate heating engineer level (see Ch. 6.5).
- ▶ Press function key Heating circuit.
- ▶ Press function key Setting #2.
- ✓ Menu Setting #2 is displayed.
- ▶ Press function key max pump speed.
- ✓ Parameter max pump speed is displayed.
- ▶ Set value using the dial knob and save with function key OK.

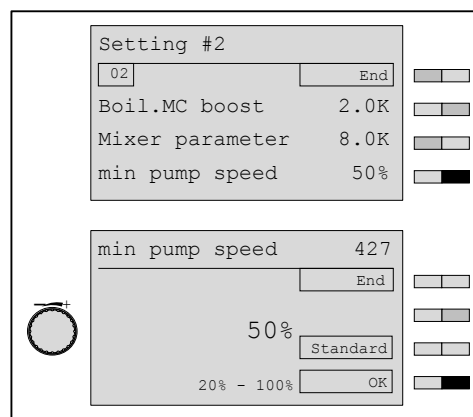

6 Operation

6.5.21 Set speed variables



Parameter is only displayed if a PWM pump is connected

Setting range

Level	Setting for condensing boilers. The pump runs with maximum speed in normal operation and with minimum speed in setback operation.
Reference line	Setting for low temperature boilers. The heating circuit pump is operated at min. speed. If the maximum supply temperature set is reached, the pump speed increases linear.

- ▶ Activate heating engineer level (see Ch. 6.5).
- ▶ Press function key Heating circuit.
- ▶ Press function key Setting #2.
- ✓ Menu Setting #2 is displayed.
- ▶ Press function key VSD variable.
- ✓ Parameter VSD variable is displayed.
- ▶ Make selection using the dial knob and save with function key OK.

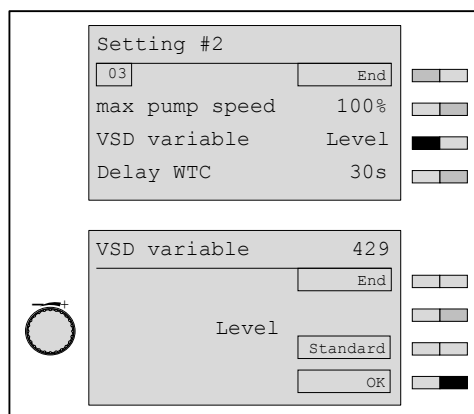

## 6 Operation

### 6.5.22 Set WTC delay

For installations with high heat exchanger ratings (WTC-GB) without hydraulic de-couple the boiler start can be delayed. During the delay time the mixer opens and the boiler has a flow prior to starting.

- ▶ Activate heating engineer level (see Ch. 6.5).
- ▶ Press function key Heating circuit.
- ▶ Press function key Setting #2.
- ✓ Menu Setting #2 is displayed.
- ▶ Press function key WTC delay.
- ✓ Parameter WTC delay is displayed.
- ▶ Set value using the dial knob and save with function key OK.

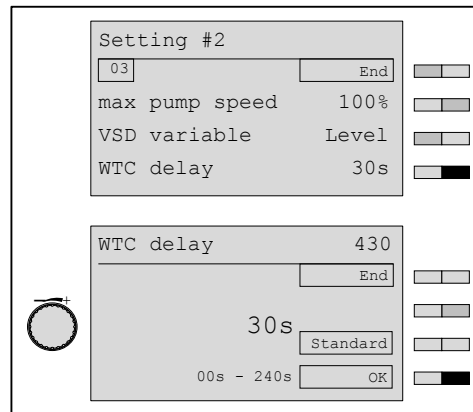

## 6 Operation

### 6.5.23 SOL yield HC

This parameter is used to stipulate, how the extension module reacts to the status messages `Excess` and `Excess temp.` from the WCM-SOL.



The parameter is only displayed, if a WCM-SOL solar controller has been fitted to the system.

- ▶ Activate heating engineer level (see Ch. 6.5).
- ▶ Press function key `Heating circuit`.
- ▶ Press function key `Setting #2`.
- ✓ Menu `Setting #2` is displayed.
- ▶ Use dial knob to move to the third menu level.
- ▶ Press function key `Sol yield HC`.
- ✓ Menu `Sol yield HC` is displayed.

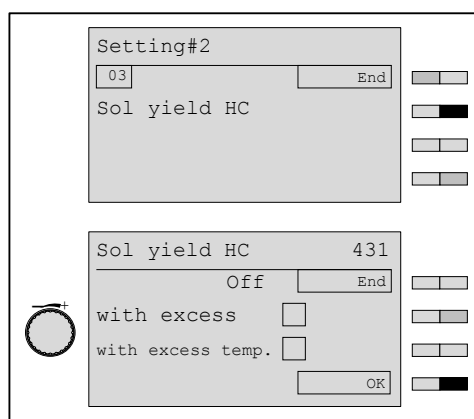

- ▶ Use function keys `with excess` and `with excess temp.` to stipulate, to which status message(s) the heating circuit should react.
- ▶ Use the dial knob to set the reaction of the heating circuit to the status messages (`Off`, `Prog. 3`, `Max. supply`).
- ▶ Confirm with function key `OK`.
- ✓ The settings are applied.

## 6 Operation

### Status messages

with excess

Is generated by the WCM-SOL 1.0, when a freely selectable temperature level (P881 in the WCM-SOL 1.0) in the buffer is exceeded due to solar input.

with excess temp.

**Diagram 1:** Is generated by the WCM-SOL 1.0, when the temperature in the DHW tank approaches the maximum design temperature.

**Diagram 2:** Is generated by the WCM-SOL 1.0, when the temperature in the DHW tank approaches the maximum design temperature.

### Reaction of the DHW load circuit

Off

The heating circuit does not react to the status messages.

Prog. 3

The heating circuit is operated according to heating program 3.

Max. supply

The heating circuit reacts by heating up to Max. supply.

### Comparison sensors for "Solar excess"

Diagram 1: B3 (DHW sensor)

Diagram 2: B10 (buffer sensor top)

### Comparison sensors for "Excess temperature"

Diagram 1: T2 (Solar sensor)

Diagram 2: B3 (DHW sensor)

6 Operation

6.5.24 Set screed program



**Damage to the fabric of the building**

It is possible that the screed function on the direct pump heating circuit could be masked by other heating circuits or by DHW operation.

► If necessary, deactivate other heating circuits.



With address setting `WTC-HC#1+EM-HC#2` the screed drying function can only be carried out for the mixer `Heating circuit#2`.



The screed function can only be carried out, if a WCM-FS remote control station has been assigned to the relevant underfloor heating circuit.

The screed program is used for the controlled drying of underlay flooring and is separated into two functions. Please observe the instructions of the screed manufacturer and DIN 4725-4.

**Function specific heating**

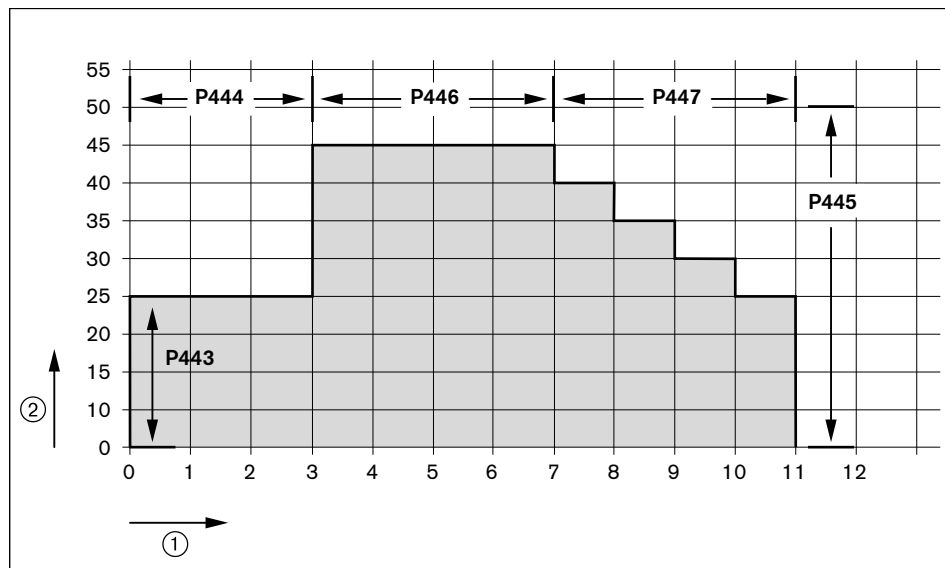

- ① Days
- ② Supply temperature °C
- P443 Start temperature
- P444 Days min. temp. FHC
- P445 Max. temp. FHC
- P446 Days max. temp. FHC
- P447 Days cooling FHC



Following power failure, the screed function will continue from the point where it was interrupted.

6 Operation

Screed heating

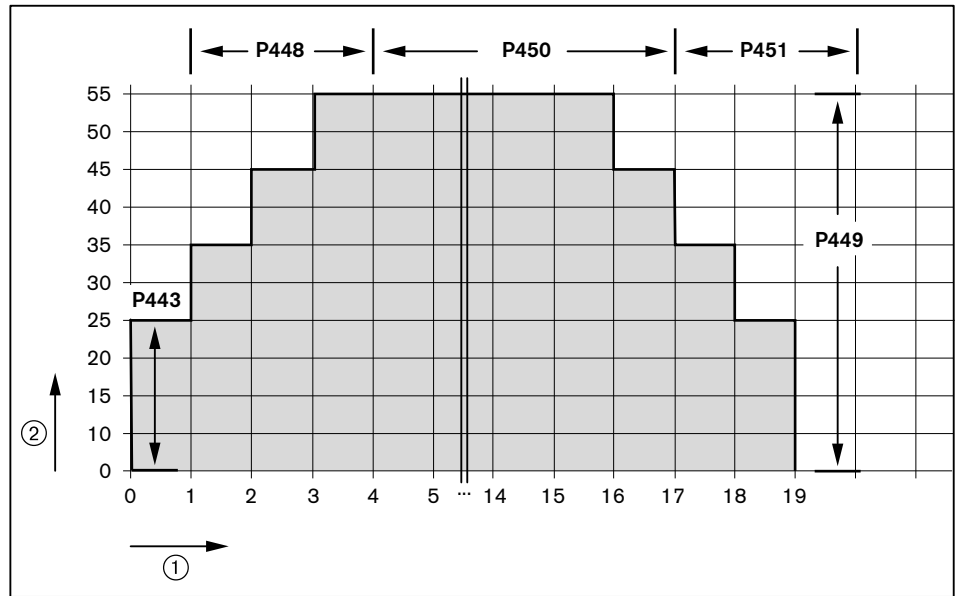

- ① Days
- ② Supply temperature °C
- P443 Start temperature
- P448 Day heat-up BHC
- P449 Max. temp. BHC
- P450 Days max. temp. BHC
- P451 Days cooling BHC

## 6 Operation

### Combined heating

The combined heating is the standard type of heating assisted screed drying. Heating is carried out to function specific heating curve and the screed heating curve.

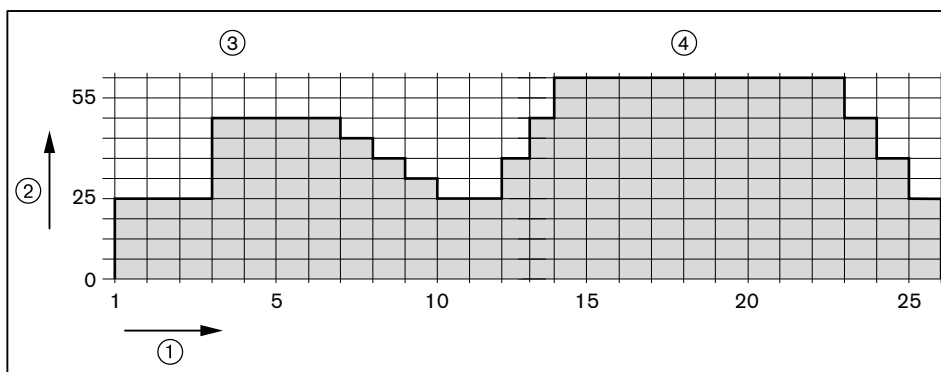

- ① Days
- ② Supply temperature °C
- ③ Function specific heating
- ④ Screed heating

- ▶ Activate heating engineer level (see Ch. 6.5).
- ▶ Press function key Heating circuit.
- ▶ Press function key Setting #2.
- ✓ Menu Setting #2 is displayed.
- ▶ Press function key Screed#2.
- ✓ Menu Screed#2 is displayed.

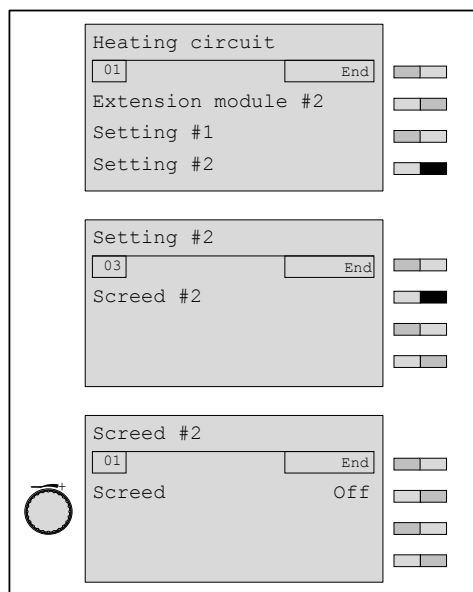

**6 Operation**

**Setting screed functions**

Off	Function inactive.
Function h	Screed stress test, has only marginal effect on drying
Screed heating	Quick drying of screed using underfloor heating
Funct/Screed	Stress test and quick drying are carried out one after the other.

- ▶ Press function key `Screed`.
- ✓ Parameter `Screed` is displayed.
- ▶ Make selection using the dial knob and save with function key `OK`.

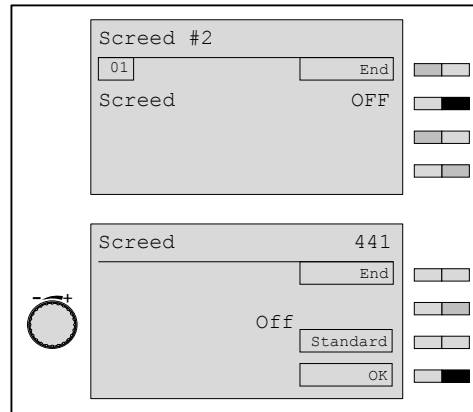

**Set screed day**

With this function, the screed days can be skipped or repeated.

Function key `Reset` resets the screed function to day 0.

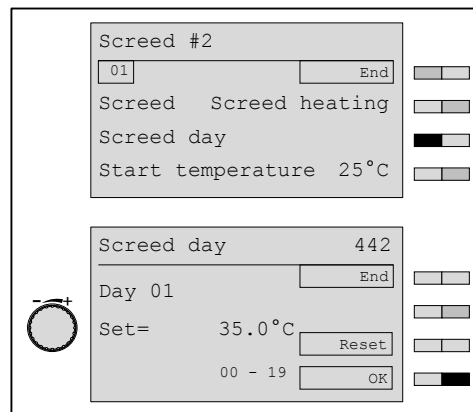

## 6 Operation

### Set start temperature

- ▶ Press function key Start temperature.
- ✓ Parameter Start temperature is displayed.
- ▶ Make selection using the dial knob and save with function key OK.

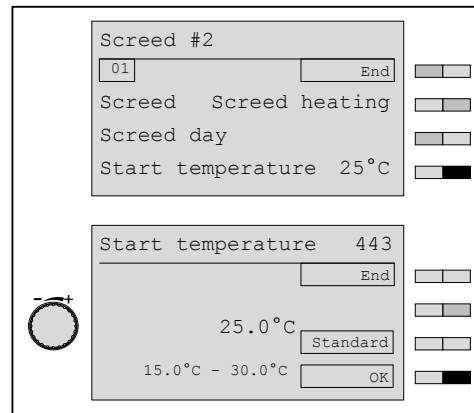

6 Operation

6.5.25 Function specific heating

Test function of underfloor heating and stress test for the screed, this is not a drying function.

- ▶ Press function key Days Min.Temp.Fht.
- ✓ Parameter Days Min.Temp.Fht is displayed.
- ▶ Make selection using the dial knob and save with function key OK.

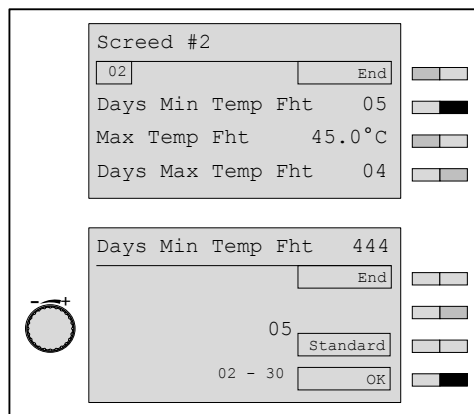

Set stress phase



The setpoint of the screed function is limited to 60°C. If the maximum supply temperature is set below 60°C, the limit is set to this value.

- ▶ Press function key Max.Temp.Fht.
- ✓ Parameter Max.Temp.Fht is displayed.
- ▶ Make selection using the dial knob and save with function key OK.

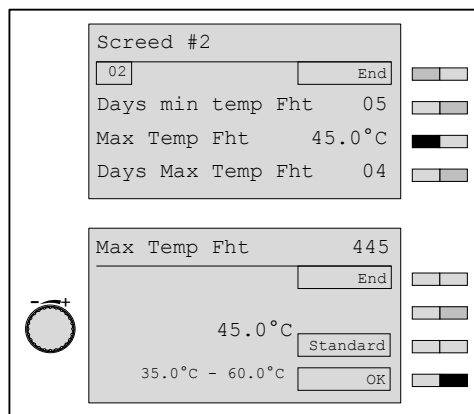

### 6 Operation

- ▶ Press function key Max.Temp.Fht.
- ✓ Parameter Max.Temp.Fht is displayed.
- ▶ Make selection using the dial knob and save with function key OK.

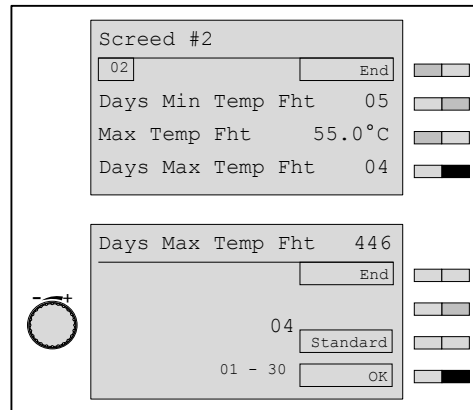

#### Set cool down phase

- ▶ Press function key Days Cooling Fht.
- ✓ Parameter Days Cooling Fht is displayed.
- ▶ Make selection using the dial knob and save with function key OK.

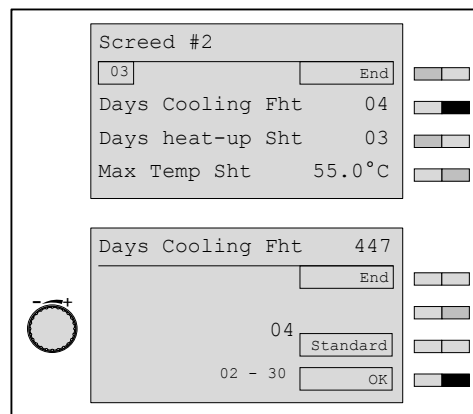

6 Operation

6.5.26 Screed heating

Quick drying of the screed up to screed readiness, follows function heating.

Set heat-up phase

- ▶ Press function key Days heat-up Sht.
- ✓ Parameter Days Cooling Sht is displayed.
- ▶ Make selection using the dial knob and save with function key OK.

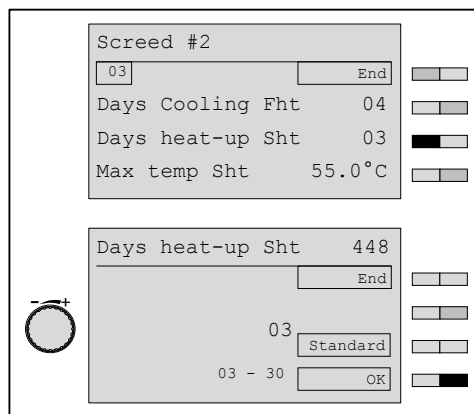

Set drying phase



The setpoint of the screed function is limited to 60°C. If the maximum supply temperature is set below 60°C, the limit is set to this value.

- ▶ Press function key Max.Temp.Sht.
- ✓ Parameter Max.Temp.Sht is displayed.
- ▶ Make selection using the dial knob and save with function key OK.

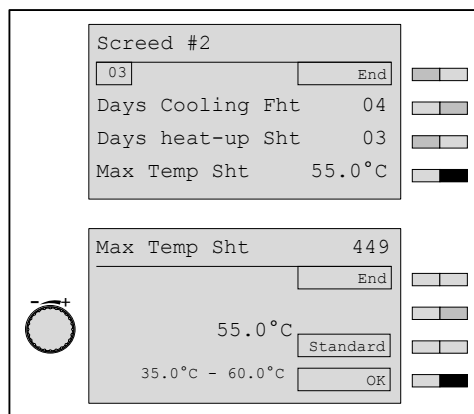

### 6 Operation

#### Set drying phase

- ▶ Press function key Days Max.Temp.Sht.
- ✓ Parameter Days Max.Temp.Sht is displayed.
- ▶ Make selection using the dial knob and save with function key OK.

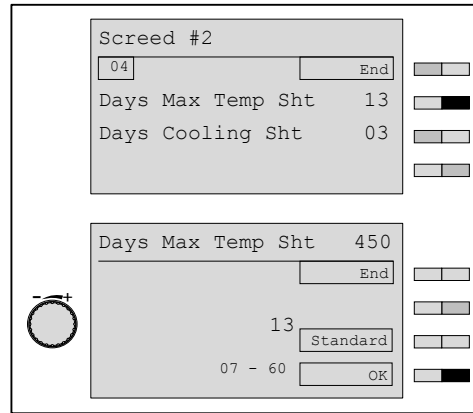

#### Set cool down phase

- ▶ Press function key Days Cooling Sht.
- ✓ Parameter Days Cooling Sht is displayed.
- ▶ Make selection using the dial knob and save with function key OK.

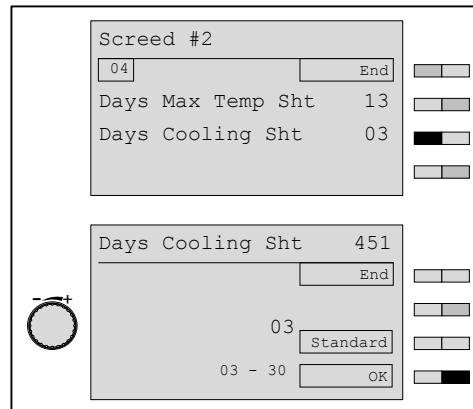

6 Operation

6.5.27 Set night setback operation



If parameter Control variable (see Ch. 6.5.8) is set to Const suppl., this parameter is not displayed.

With this parameter the control behaviour in setback operation is defined. This setting applies for the operation in heating program 1... 3 as well as the presence and absence function. If the external sensor fails, an automatic change-over from Frost to Setback is initiated.

Setting range

Frost	If the external temperature falls below the frost protection temperature set, the controller activates the frost heating operation. The supply setpoint is generated via parameter 118 Room frost temp (user level). Suitable for buildings with high insulation values.
Setback	The supply temperature is defined in accordance with the setback temperature setpoint depending on the gradient set. The heating circulation pump continues to operate. This is activated automatically if the external sensor fails.

- ▶ Activate heating engineer level (see Ch. 6.5).
- ▶ Press function key Heating circuit.
- ▶ Press function key Control behaviour.
- ✓ Menu Control behaviour is displayed.
- ▶ Press function key Reduced oper..
- ✓ Parameter Reduced oper. is displayed.
- ▶ Make selection using the dial knob and save with function key OK.

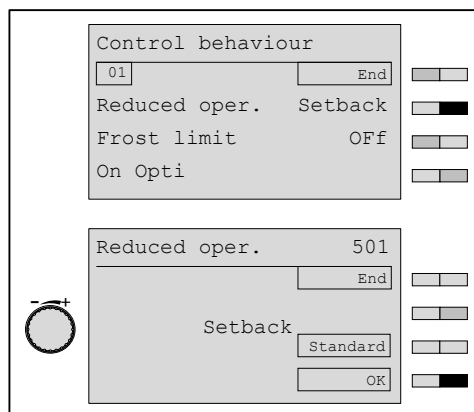

**6 Operation**

**6.5.28 Set frost limit**

If the external temperature falls below the frost protection limit set, the control behaviour in setback operation changes from Frost to Setback or from Setback to Normal. The absence function is ignored. The frost protection limit is only effective with heating program 1 ... 3. The time cursor is not influenced by the frost limit and therefore not displayed continuously. The response of the frost protection limit is shown in the standard display with function key i (Status#...) (see operating instructions WCM-FS).

**Setting range**

Off  
 -20°C ... 0.0

- ▶ Activate heating engineer level (see Ch. 6.5).
- ▶ Press function key Heating circuit.
- ▶ Press function key Control behaviour.
- ✓ Menu Control behaviour is displayed.
- ▶ Press function key Frost limit.
- ✓ Parameter Frost limit is displayed.
- ▶ Set value using the dial knob and save with function key OK.

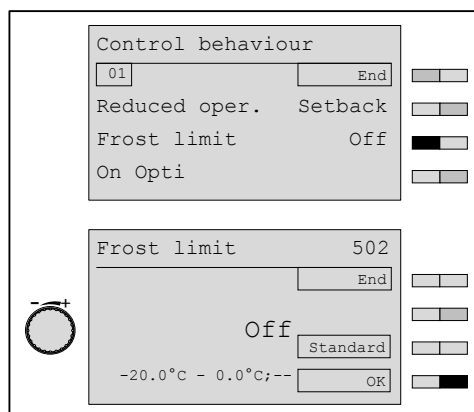

6 Operation

6.5.29 Set switch on optimisation



This parameter is only displayed, if room or weather compensation has been activated in level Type of control#1 (see Ch. 6.5.8).

To ensure the room setpoint temperature has been reached at the beginning of normal operation (heating program), the switch on time is preset. The parameter *On Opti* limits the maximum time of the pre-setting. At *Curr* the current pre-set time calculated is displayed.

**Room dependent variation (pre-setting based on the actual room temperature)**

Setting parameter 318 *Room* or *External/Room* (see Ch. 6.5.8).

The optimisation function is reset to the maximum value:

- after resetting of the WCM-FS,
- after resetting of parameter via function key 2,
- after changing parameter heating circuit type (P316).

**Weather dependent variation (pre-setting based on the external temperature)**

Setting parameter 318 *External* (see Ch. 6.5.8).

**Setting range**

Off  
00:15 ... 04:00 h

- ▶ Activate heating engineer level (see Ch. 6.5).
- ▶ Press function key *Heating circuit*.
- ▶ Press function key *Control behaviour*.
- ✓ *Menu Control behaviour* is displayed.
- ▶ Press function key *On Opti*.
- ✓ *Parameter On Opti* is displayed.
- ▶ Set value using the dial knob and save with function key *OK*.

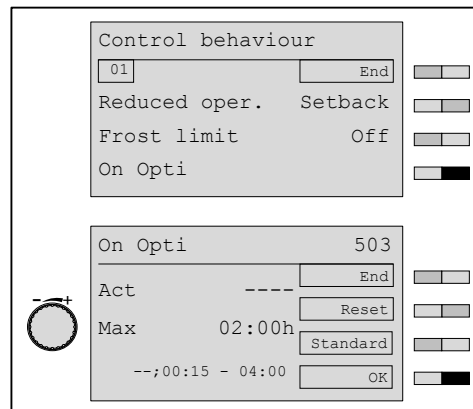

## 6 Operation

### 6.5.30 Set type of building

With this parameter the control is matched to the construction of the building.

#### Setting range

light	Building with light brickwork or little insulation.
heavy	Building with heavy brickwork or good insulation.

- ▶ Activate heating engineer level (see Ch. 6.5).
- ▶ Press function key Heating circuit.
- ▶ Press function key Control behaviour.
- ✓ Menu Control behaviour is displayed.
- ▶ Press function key Type of building.
- ✓ Parameter Type of building is displayed.
- ▶ Make selection using the dial knob and save with function key OK.

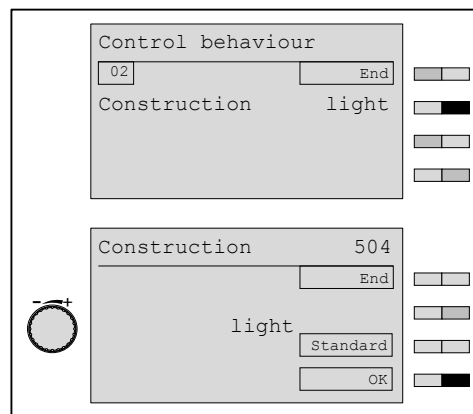

6 Operation

6.5.31 Set room thermostat#1 ... 8



Parameter Room thermostat#1 ... 8 is display, when parameter 318 has been set to Room or External/Room.

The heating circuit switches off when the room setpoint value is exceeded by the switch differential set.

Setting range

Off	Room thermostat function off
Day Off	Function only in setback operation with switch differential of 1 K.
1.0K ... 3.0K	Switch differential for switch-off

- ▶ Activate heating engineer level (see Ch. 6.5).
- ▶ Press function key Heating circuit.
- ▶ Press function key Control behaviour.
- ✓ Menu Control behaviour is displayed.
- ▶ Press function key Room ther#1.
- ✓ Parameter Room ther#1 is displayed.
- ▶ Set value using the dial knob and save with function key OK.

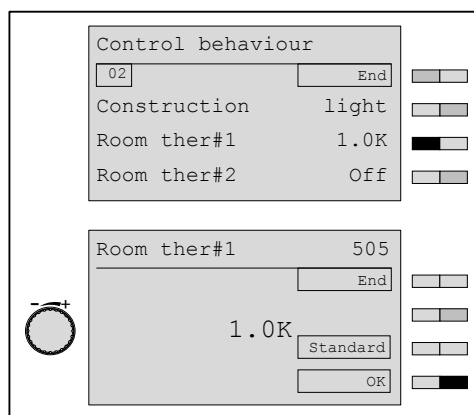

6 Operation

6.5.32 Set adaption#1 ... 8

The adaption is used to automatically match the gradient to the building.



The parameter is only displayed, if P315 is set to External/Room.

Setting range

Off	Adaption inactive.
On	Adaption effective. Gradient is being adjusted.

Prerequisite for an adaption:

- External temperature max. 8 °C,
- setback operation of min. 6 hours must be set,
- parameter 318 must be set to External/Room,
- automatic operation (heating program 1 ... 3).
- ▶ Activate heating engineer level (see Ch. 6.5).
- ▶ Press function key Heating circuit.
- ▶ Press function key Control behaviour.
- ✓ Menu Control behaviour is displayed.
- ▶ Press function key Adaption#1.
- ✓ Parameter Adaption#1 is displayed.
- ▶ Set ON using the dial knob and save with function key OK.

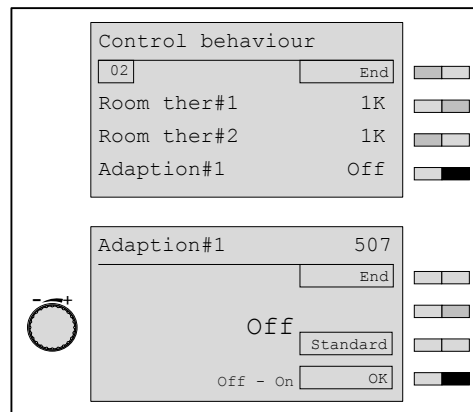

Active adaption is displayed:

- in line 4 of the standard display by A,
- i Info mode by Adaption.

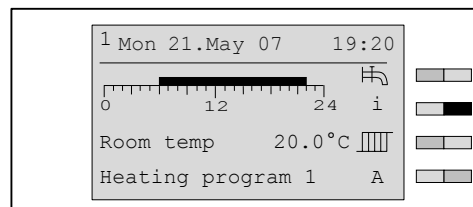

During the adaption:

- Do not manually correct the heating reference line
- Do not change room temperature setpoint
- Do not interrupt voltage supply
- Radiator thermostats must be open
- External heat sources must be switched off

Following completed adaption, the A in the standard display is faded out.

## 6 Operation

### 6.5.33 Set room factor-P

The higher the value set, the more influence the room temperature will have on the supply setpoint formation.



Parameter is only displayed, if parameter 315/316 Control type#1/Control type#2 is set to Room or External/Room (see Ch. 6.5.8).

- ▶ Activate heating engineer level (see Ch. 6.5).
- ▶ Press function key Heating circuit.
- ▶ Press function key Control behaviour.
- ✓ Menu Control behaviour is displayed.
- ▶ Press function key Room factor-P.
- ✓ Parameter Room factor-P is displayed.
- ▶ Set value using the dial knob and save with function key OK.

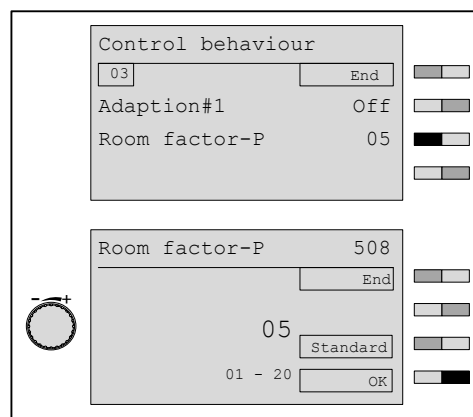

6 Operation

6.5.34 Set maximum DHW temperature



**Danger of scalding by hot water**

Water temperatures above 60 °C can lead to serious scalding if they come into contact with the skin.

- ▶ Activate heating engineer level (see Ch. 6.5).
- ▶ Press function key DHW.
- ✓ Menu DHW is displayed.
- ▶ Press function key DHW maximum.
- ✓ Parameter DHW maximum is displayed.
- ▶ Set value using the dial knob and save with function key OK.

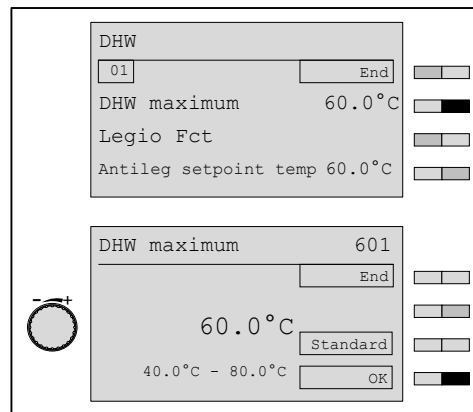

## 6 Operation

### 6.5.35 Set DHW switch differential

The setting of the DHW switch differential stipulates at what point the hot water tank is heated up again if the DHW setpoint is not maintained.

- ▶ Activate heating engineer level (see Ch. 6.5).
- ▶ Press function key **DHW**.
- ✓ Menu **DHW** is displayed.
- ▶ Press function key **DHW switch diff.**
- ✓ Parameter **DHW switch diff** is displayed.
- ▶ Set value using the dial knob and save with function key **OK**.

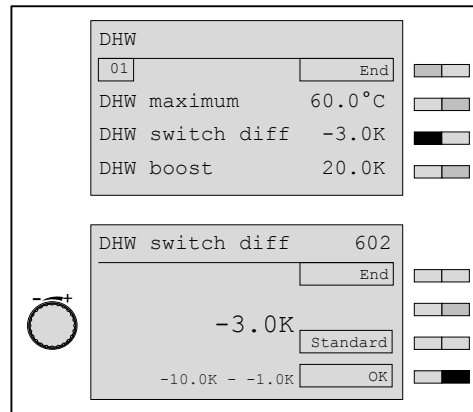

## 6 Operation

### 6.5.36 Set DHW boost

DHW loading is only possible, if the boiler temperature is higher than the DHW setpoint. The boiler temperature (supply) for DHW loading is determined from the DHW setpoint and the DHW boost. If a lower value is set, the DHW loading time increases. If a higher value is set, the DHW loading time decreases, which is detrimental to the condensate utilisation.

- ▶ Activate heating engineer level (see Ch. 6.5).
- ▶ Press function key **DHW**.
- ✓ Menu **DHW** is displayed.
- ▶ Press function key **DHW boost**.
- ✓ Parameter **DHW boost** is displayed.
- ▶ Set value using the dial knob and save with function key **OK**.

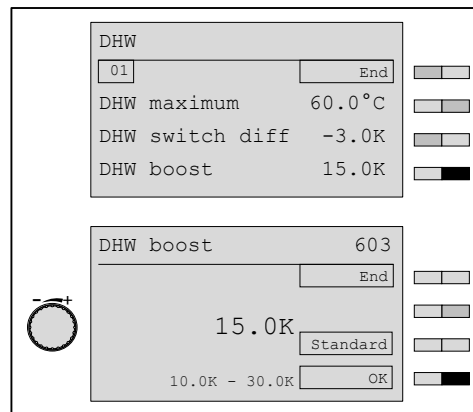

## 6 Operation

### 6.5.37 Set maximum DHW load time

To avoid cooling of the heated rooms during DHW loading (DHW priority), the time for DHW loading can be limited.

If DHW loading is not completed in the time set, the system changes to heating operation for the same period of time and then changes back to DHW operation.

- ▶ Activate heating engineer level (see Ch. 6.5).
- ▶ Press function key **DHW**.
- ✓ Menu **DHW** is displayed.
- ▶ Use dial knob to move to the second menu level.
- ▶ Press function key **Max load time DHW**.
- ✓ Parameter **Max load time WW** is displayed.
- ▶ Set value using the dial knob and save with function key **OK**.

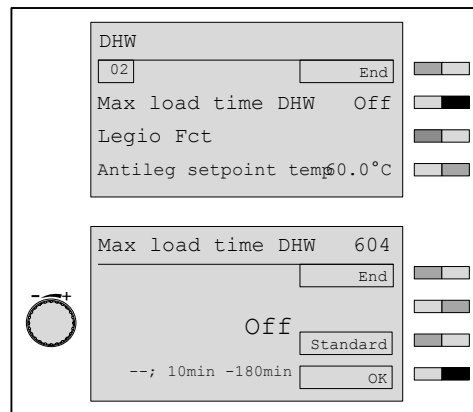

6 Operation

6.5.38 Set Legionella protection function



**Danger of scalding by hot water**

Water temperatures above 60 °C can lead to serious scalding if they come into contact with the skin.

DHW is heated to the Legionella setpoint temperature on preset days, this thermally disinfects the water. The Legionella protection function is also carried out in Standby and during the holiday program.

**Solar utilisation**

If solar utilisation is activated, the DHW temperature will be monitored for overheating during the time intervals set.



Once a week solar utilisation must not be selected, if weekly Legionella protection function is compulsory. It is possible that the interval could be extended by up to 9 days.



In conjunction with a WTC 25-A vers. C this parameter is not displayed.

**Setting range**

Legionella protection function Parameter 605	Solar utilisation
Once a week Monday Tuesday ... Sunday	If, from the 4. day after the last Legionella protection function, the current Antilegionella setpoint temperature set, the Legionella protection function is carried out by the operation of the circulation pump. Therefore the next Legionella protection function is carried out on the day set.
daily	If, 12 hours after the time set, the current DHW temperature exceeds the Antilegionella setpoint temperature, the Legionella protection function is carried out by the operation of the circulation pump. Therefore the next Legionella protection function is carried out at the time set.

## 6 Operation

- ▶ Activate heating engineer level (see Ch. 6.5).
- ▶ Press function key **DHW**.
- ✓ Menu **DHW** is displayed.
- ▶ Press function key **Legio Fct**.
- ✓ Parameter **Legio Fct** is displayed.
- ▶ Make selection using the dial knob and save with function key **OK**.

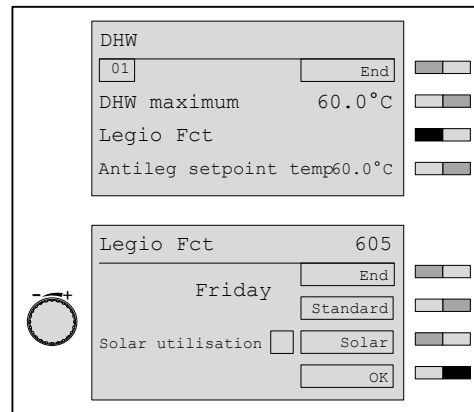

6 Operation

6.5.39 Set Antilegionella setpoint temperature

The function Antilegionella setpoint temperature is the disinfection temperature, to which the hot water tank heats up during the Antilegionella function.



In conjunction with a WTC 25-A vers. C this parameter is not displayed.

- ▶ Activate heating engineer level (see Ch. 6.5).
- ▶ Press function key **DHW**.
- ✓ Menu **DHW** is displayed.
- ▶ Use dial knob to move to the second menu level.
- ▶ Press function key **Antileg setpoint temp.**
- ✓ Menu **Antileg setpoint temp** is displayed.
- ▶ Set temperature using the dial knob and save with function key **OK**.

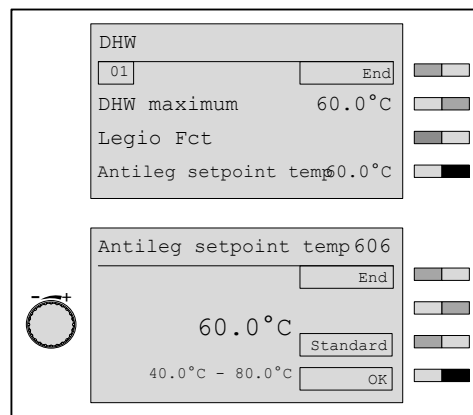

6 Operation

6.5.40 Set Legionella time



In conjunction with a WTC 25-A vers. C this parameter is not displayed.

- ▶ Activate heating engineer level (see Ch. 6.5).
- ▶ Press function key **DHW**.
- ✓ Menu **DHW** is displayed.
- ▶ Press function key **Legio time**.
- ✓ Parameter **Legio time** is displayed.
- ▶ Set value using the dial knob and save with function key **OK**.

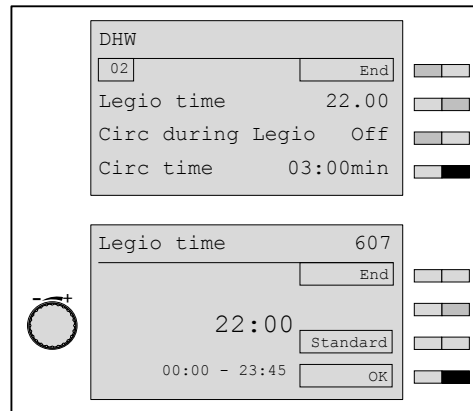

6 Operation

6.5.41 Activate circulation during Legionella protection function



In conjunction with a WTC 25-A vers. C this parameter is not displayed.

Setting range

On	Circulation is active during the entire disinfection process. If the pipework is long this setting leads to high heat loss.
Off	Operation of the circulation pump at the end of the Legionella protection function for the duration set in parameter 609 (see Ch. 6.5.42).

- ▶ Activate heating engineer level (see Ch. 6.5).
- ▶ Press function key **DHW**.
- ✓ Menu **DHW** is displayed.
- ▶ Press function key **Circ** during **Legio**.
- ✓ Parameter **Circ during Legio** is displayed.
- ▶ Set **ON** using the dial knob and save with function key **OK**.

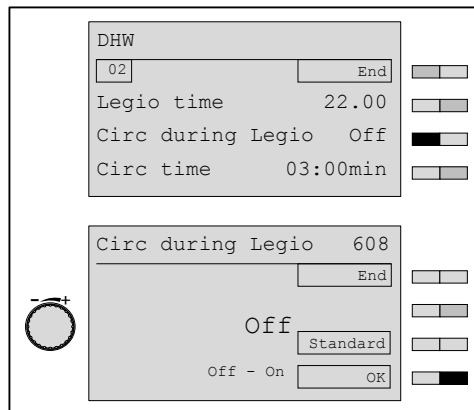

## 6 Operation

### 6.5.42 Set circulation time

The parameter stipulates the run time of the circulation pump:

- with the DHW Boost function,,
  - following completion of the Legionella protection function,
  - after activation of H1 contact on the WCM-EM in DHW operation.
- ▶ Activate heating engineer level (see Ch. 6.5).
- ▶ Press function key *DHW*.
- ✓ Menu *DHW* is displayed.
- ▶ Press function key *Circ time*.
- ✓ Parameter *Circ time* is displayed.
- ▶ Set value using the dial knob and save with function key *OK*.

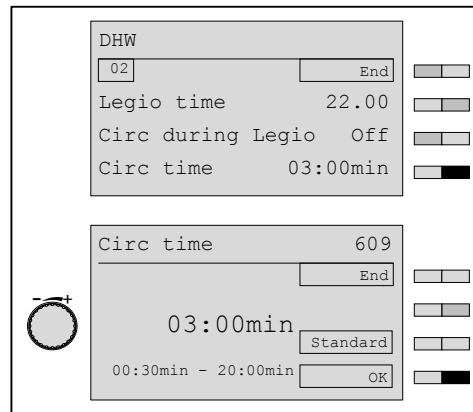

6 Operation

6.5.43 Set circulation return temperature



The parameter is only displayed, if a surface contact temperature sensor NTC 5 kΩ is connected to the WCM-EM input B1.

The circulation pump is activated until the temperature set is reached. If the temperature at sensor B1 exceeds the value set, the circulation pump is switched off. After cooling below a switch differential during the circulation program the circulation pump is switched on again.

- ▶ Activate heating engineer level (see Ch. 6.5).
- ▶ Press function key **DHW**.
- ✓ Menu **DHW** is displayed.
- ▶ Press function key **Circ temp**.
- ✓ Parameter **Circ temp** is displayed.
- ▶ Set value using the dial knob and save with function key **OK**.

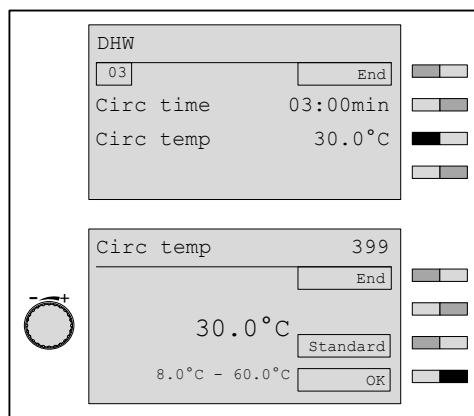

## 6 Operation

### 6.5.44 SOL Yield DHW

This parameter is used to stipulate, if and how the DHW module reacts to the status messages `Excess` and `Excess temp.` from the WCM-SOL.

- ▶ Activate heating engineer level (see Ch. 6.5).
- ▶ Press function key `DHW`.
- ✓ Menu `DHW` is displayed.
- ▶ Use dial knob to move to the fourth menu level.
- ▶ Press function key `Sol Yield DHW`.
- ✓ Menu `Sol Yield DHW` is displayed.

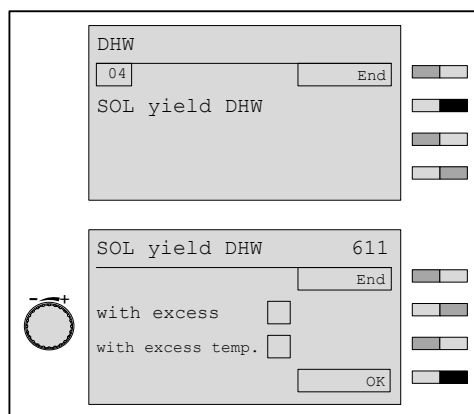

- ▶ Use function keys `with excess` and `with excess temp.` to stipulate, to which status message(s) the DHW load circuit should react.
- ▶ Use the dial knob to set the reaction of DHW loading to the status messages (`Off`, `Normal DHW setpoint`, `maximum DHW`).
- ▶ Confirm with function key `OK`.
- ✓ The settings are applied.

#### Status messages

<code>with excess</code>	Is generated by the WCM-SOL 1.0, when a freely selectable temperature level (P881 in the WCM-SOL 1.0) in the buffer is exceeded due to solar input.
<code>with excess temp.</code>	<p><b>Diagram 1:</b> Is generated by the WCM-SOL 1.0, when the temperature in the DHW tank approaches the maximum design temperature</p> <p><b>Diagram 2:</b> Is generated by the WCM-SOL 1.0, when the temperature in the DHW tank approaches the maximum design temperature</p>

#### Reaction of the DHW load circuit

<code>Off</code>	The DHW load circuit does not react to the status messages.
<code>Normal DHW setpoint</code>	The DHW load circuit reacts by heating up to the normal level for DHW.
<code>DHW maximum</code>	The DHW load circuit reacts by heating up to DHW maximum.

## 6 Operation

### 6.5.45 Central control via control centre

This function is used to access parameters of extension modules WCM-EM without remote control station WCM-FS assigned.

In menu `Access HC w/o. FS`:

- Extension modules without remote control station are programmed. The time cursor in the standard display shows only the DHW program.
- All parameters of the WCM-EM are displayed ( --- is displayed as the parameter value for any parameters that cannot be adjusted).

When using a control centre only address `EM-HC#2 ... #8` can be set at the eBUS. Addresses `WTC-HC#1` and `WTC-HC#1+EM-HC#2` are not permitted.

Settings, which are outside of the value range, are limited to the min. /or max. value once saved.



Using a WCM-FS addressed as a control centre (#L) the type of operation of one or more WCM-EM extension modules (without WCM-FS assigned) can be controlled centrally. To do this, type of operation P111 of the WCM-EM extension modules to be controlled must be set "Control centre".

- ▶ Activate end user level (see Ch. 6.5).
- ▶ Turn dial knob until `Access HC w/o. FS` appears.
- ▶ Press function key `Access HC w/o. FS`.
- ✓ Menu `Access HC w/o. FS` is displayed.
- ▶ Press function key `EM-HC#2`.
- ✓ Menu `End user#2` is displayed highlighted black.

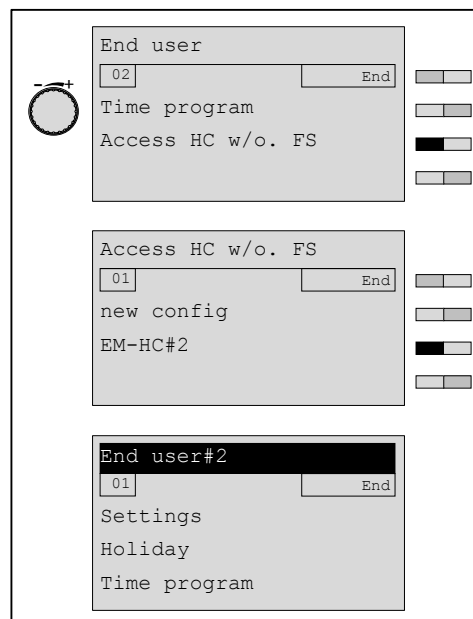

### 6 Operation

- ▶ In level End user#2 press function key Settings#2.
- ✓ Menu Settings#2 is displayed.
- ▶ Press function key Type of operation HC#2
- ✓ Parameter Type of operation HC#2 is displayed.
- ▶ Set Control centre using the dial knob and save with function key OK.
- ▶ Exit menu using the menu key.

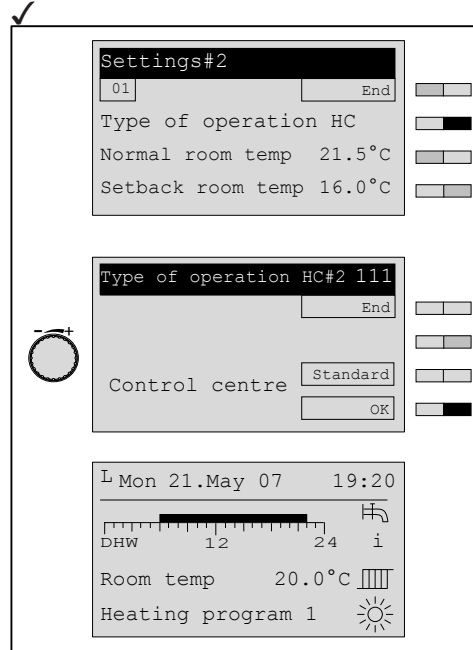

Once the WCM-EM extensions modules to be controlled have been set to "Control centre", the type of operation and the holiday function will be carried out to the settings made in WCM-FS address #L.

**6 Operation**

**6.6 Extension module menu structure**

**6.6.1 Extension module EM-HC (access HC without FS)**



Depending on the scope of the system some parameters may not be displayed. Screenshot function only possible with WCM-FS remote control station assigned.

Menu point	Parameters	Description	Factory pre-setting	Set		
Commissioning	P336	Config EM#X	-			
	P313	HC-Type#X	Universal			
	P315	Type of controller#X	External			
Heating circuit	Extension module	P402	H1-Fct HC#X	Standby		
		P403	Output test HC#X	-		
		P405	Correct external sensor#X	-		
	Settings	P421	Supply min#X	8°C		
		P422	Supply max#X	75°C		
		P423	DHW operation#X	Priority		
		P424	Boiler-MC boost#X	2K		
		P425	Mixer parameter#X	8K		
		P426	Frost protection#X	5°C		
		P427	min pump speed#X	-		
		P428	max pump speed#X	-		
		P429	Speed variable#X	-		
		P430	Delay WTC#X	30 sec		
		P431	SOL Yield HC#X	Off		
	Control behaviour	P501	Reduced oper#X	Setback		
		P502	Frost limit#X	Off		
		P503	On Opti#X	2h		
		P504	Construction#X	light		
	Heating circuit info	P521	External EM-HC#X	current	°C	
				dampened	°C	
				mixed	°C	
		P523	Supply#X	°C		
		P524	DHW#X	-		
		P525	Circ temp	-		
			Setpoint temp#X	-		
		P341	Version EM-HC#X	-		

**6 Operation**

**6.6.2 Extension module EM-DHW (access HC without FS)**



Depending on the scope of the system some parameters may not be displayed

Menu point	Parameters	Description	Factory pre-setting	Set	
Commissioning	P366	Config EM#X	-		
Heating circuit#X	Extension module #X	P401	H1-Fct DHW#X	Standby	
		P404	Output test DHW#X	-	
	Heating circuit info	P523	Supply#X	°C	
		P524	DHW#X	°C	
		P525	Circ temp	°C	
		P341	Version EM-DHW#X	-	
	DHW	P601	DHW maximum	60°C	
		P602	DHW switch diff	-3°C	
P603		DHW boost	15K		
P604		Max DHW load time	10 min		
P605		Legio fct	Friday		
P606		Antileg setpoint temp	60.0°C		
P607		Legio Time	22 hrs		
P608		Circ during Legio	Off		
P609		Circ time	3 min		
P610		Circ temp	30.0°C		
P611		SOL yield DHW	-		

## 6 Operation

### 6.7 Reset WCM-EM

Reset is used to return the WCM-EM to the factory settings. Reset is required, when the functions heating circuit or DHW load circuit of the WCM-EM are changed.

- ▶ Set address switch on WCM-EM to A (see Ch. 7.1.1).
- ✓ All LED's are flashing. After approx. 10 sec. all standard values are loaded and the LED's go on in sequence (see Ch. 6.3).
- ▶ Set address on the WCM-EM (see Ch. 7.1.1).
- ✓ WCM-EM determines all sensors and actuators connected.

### 6.8 Reconfiguring WCM-EM for system alterations

- ▶ Disconnect power supply to WCM-EM.
- ▶ Carry out installation modification.
- ▶ Reconnect power supply to WCM-EM.
- ✓ It is possible that the WCM-FS assigned signals an error.
- ▶ Re-identify configuration WCM-EM (see Ch. 6.5.6).

### 6.9 Emergency operation WCM-EM

Emergency operation temporarily bridges a fault condition. The WCM-EM must not be operated in emergency mode for a prolonged period of time. With address setting F the output relay for the mixer heating circuit pump is switched on.

- ▶ Set address switch on WCM-EM to F (see Ch. 7.1.1).
- ✓ Mains LED and eBUS LED flash in impulse/pause ratio 50 % On and 50 % Off (see Ch. 6.3).

## 6 Operation

### 6.10 Reset WCM-FS



When resetting the remote control station, all previous setting will be reset to factory settings.

Reset of the WCM-FS is required, when a reset has been carried out on the extension module or modules, because the function of the heating circuit or the DHW load circuit has changed.

- ▶ Remove remote control station from its holder.
- ▶ Press and hold menu key whilst refitting it to the bracket.
- ▶ Press and hold the menu key, until `EEPROM` appears in the display.

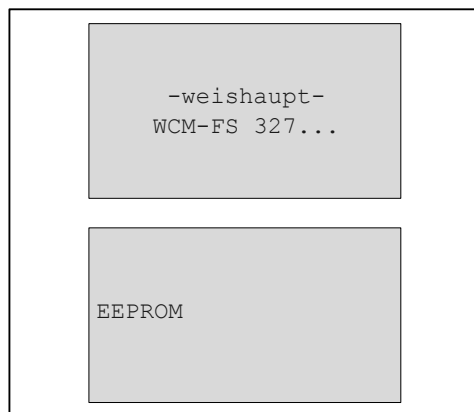

- ▶ Select language (see Ch. 7.2.1).
- ▶ Set address (see Ch. 7.2.2).
- ✓ The remote control station is being reconfigured. The display shows the system start.

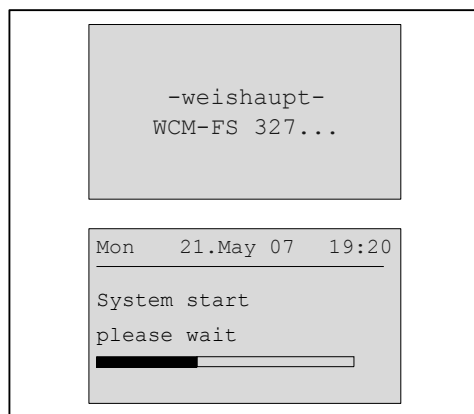

- ▶ Carry out commissioning (see Ch. 7).

## 7 Commissioning

### 7 Commissioning

The menu Commissioning is displayed automatically:

- during initial commissioning,
- after every reset.

#### 7.1 Prerequisite



##### Possible damage to the equipment!

Incorrectly carried out assembly, installation and commissioning can lead to failure of individual devices or the entire heating system. Only correctly carried out commissioning ensures the operational safety of the entire system.

- ▶ The commissioning may only be carried out by qualified personnel.

- ▶ Please check that all installation work has been completed prior to commissioning.

#### 7.1.1 Set address on WCM-EM

The same address must be set on the extension module and the remote control station assigned (see Ch. 7.2.2).

- ▶ Check, and if necessary, set eBUS address on extension module.

- |     |   |
|-----|---|
| 1   | Function not defined  |
| 2   | eBUS address of EM#2 (heating circuit 2)                    |
| 3   | eBUS address of EM#3 (heating circuit 3)                    |
| 4   | eBUS address of EM#4 (heating circuit 4)                    |
| 5   | eBUS address of EM#5 (heating circuit 5)                    |
| 6   | eBUS address of EM#6 (heating circuit 6)                    |
| 7   | eBUS address of EM#7 (heating circuit 7)                    |
| 8   | eBUS address of EM#8 (heating circuit 8)                    |
| A   | Reset   |
| B-E | Function not defined  |
| F   | Emergency operation (temporarily bridges a fault condition) |

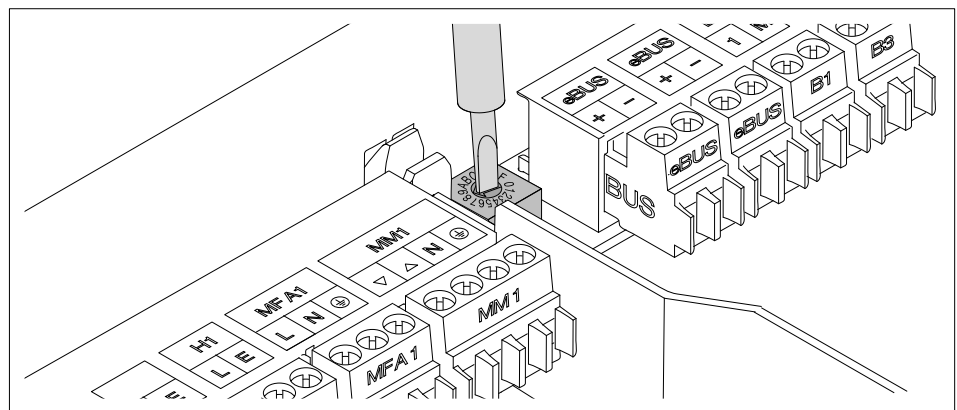

The extension module controls the eBUS supply automatically, not other measures are required.

## 7 Commissioning

### 7.2 Steps for commissioning



During commissioning you will automatically be guided through the setting menus required.

#### 7.2.1 Setting the language

When initially applying voltage when switching on the unit and after every reset, parameter *Language* is displayed (see Ch. 6.5.4).

- ▶ Set language using the dial knob.
- ▶ Save with function key *OK*.

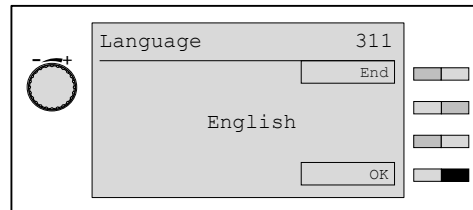

#### Selectable languages

Deutsch  
English  
Français  
Italiano  
Espanol  
Nederlands  
Dansk  
Svenska  
Norsk  
Slovenski  
Hrvatski  
Magyar  
Polski  
Русский  
Cesky  
Slovak

## 7 Commissioning

### 7.2.2 Set address on the WCM-FS

The address can only be set:

- during initial commissioning,
- after every reset (see Ch. 6.10).

Display	Functional assignment
Control centre #L	Control centre function (see Ch. 6.5.45)
WTC-HC#1	Direct pump heating circuit on the WTC
EM-HC#2 <sup>(1)</sup> ... EM-HC#8 <sup>(1)</sup>	Heating circuit WCM-EM#2 ... WCM-EM#8
WTC-HC#1+ EM-HC#2	Control variables: Room heated with the direct pump heating circuit WTC #1 and heating circuit EM#2

<sup>(1)</sup> the address of the WCM-FS must concur with the address of the WCM-EM assigned (see Ch. 7.1.1).

- ▶ Set address using the dial knob.
- ▶ Save with function key OK.
- ✓ Remote control station is being configured..

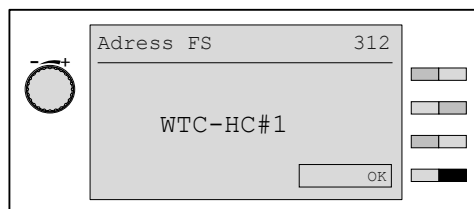

### Configuration

The Software version is displayed briefly, then the remote control station is reconfigured.

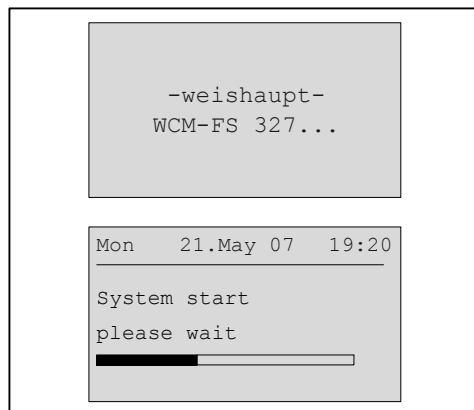

## 8 Troubleshooting

### 8 Troubleshooting

#### 8.1 Error codes

Error messages from all eBUS participants are displayed. A description of the individual errors can be found in the relevant installation and operating instructions.

The WCM-FS only displays errors, which last 15 minutes or more. Errors and rectified errors are stored in the error history with error source, error code, date and time. Rectified errors are displayed with error code 00.

##### Sensor faults

Error code	Cause	Error source	Rectification
130	Supply sensor B6 defective	WCM-EM-HC	▶ Replace supply sensor.
132	De-couple sensor defective	WCM-KA/ CPU	▶ Replace de-couple sensor.
133	External sensor B1 defective	WCM-EM-HC	▶ Replace external sensor.
134	DHW sensor B3 defective	WCM-EM- DHW	▶ Replace DHW sensor.
135	Circulation sensor B1 defective	WCM-EM- DHW	▶ Replace circulation sensor.
136	External room sensor defective	WCM-EM-HC	▶ Replace room sensor on the WCM-FS.
137	Internal room sensor defective	WCM-EM-HC	▶ Replace WCM-FS.

##### Actuator fault

Error code	Cause	Error source	Rectification
142	PWM pump defective	WCM-EM/ CPU	▶ Check pump and replace if necessary.

##### Unit fault

Error code	Cause	Error source	Rectification
154	Error EEPROM	–	▶ Reset unit (see Ch. 6.7)

##### eBUS communication error

Error code	Cause	Error source	Rectification
180	Communication error to WCM-KA	WCM-FS	▶ Check eBUS lines, Bus level and protocol, if necessary fit screen cables.
181 ... 188	Communication error to WCM-FS	WCM-KA	▶ See installation and operating instructions Cascade Manager WCM-KA 2.0.
189	Error N1 input	WCM-KA	▶ See installation and operating instructions Cascade Manager WCM-KA 2.0.
190	Communication error to WCM-EM	WCM-FS	▶ Check eBUS lines, Bus level and protocol, if necessary fit screen cables.
191 ... 198	Communication error to WCM-CPU	WCM-FS	▶ Check eBUS lines, Bus level and protocol, if necessary fit screen cables.

**8 Troubleshooting**

**System error**

- ▶ Rectify system error.
- ▶ Switch system off and on.
- ✓ System is being reconfigured.

<b>Error code</b>	<b>Cause</b>	<b>Error source</b>	<b>Rectification</b>
200	Bus identification occupied, 2 identical WCM-EM and WCM-FS	–	▶ Set different eBUS address on WCM-FS.
201	Address W unit in cascade system	–	▶ Check, if DHW assembly has been installed on unit #A.
202	WCM-FS address $WTC-HC\#2+EM-HC\#2$ has been assigned to a DHW load circuit	–	▶ Set different eBUS address.

9 Technical documentation

9 Technical documentation

9.1 Sensor variables

External sensor (QAC 31)

Contact sensor  
Circulation sensor  
Supply sensor  
External room sensor

DHW sensor

NTC 600Ω		NTC 5 kΩ		NTC 12 kΩ	
°C	Ω	°C	Ω	°C	Ω
-35	672	-20	48180	-15	71800
-30	668	-15	36250	-10	55900
-25	663	-10	27523	-5	44000
-20	657	-5	21078	0	35500
-15	650	0	16277	5	27700
-10	642	5	12669	10	22800
-8	638	10	9936	15	17800
-6	635	15	7849	20	14800
-4	631	20	6244	25	12000
-2	627	25	5000	30	9800
0	623	30	4029	35	8300
2	618	35	3267	40	6600
4	614	40	2665	45	5400
6	609	45	2185	50	4500
8	605	50	1802	55	3800
10	600	55	1494	60	3200
12	595	60	1245	65	2700
14	590	65	1042	70	2300
16	585	70	876	75	2000
18	580	75	740	80	1700
20	575	80	628	85	1500
22	570	85	535	90	1300
24	565	90	457		
26	561	95	393		
28	556	100	338		
30	551	105	292		
35	539	110	254		

10 Key word index

<b>A</b>		<b>H</b>	
Adaption .....	79	Heat exchanger interlock .....	50
Address .....	93, 99, 101	Heating circuit pump .....	23
Ambient conditions .....	14	Heating circuit type .....	45
Approval data .....	14	Heating engineer level .....	25, 32
<b>B</b>		Heating program .....	25
Boiler mixing circuit boost .....	56	Hot water load pump .....	24
Boiler start .....	62	Housing cover .....	20
Buffer control .....	43	<b>I</b>	
<b>C</b>		Illumination .....	25
Cable cross section .....	19	Input .....	23, 24, 50
Circulation .....	90	Installation modification .....	97
Circulation pump .....	24, 50, 51, 90, 91	<b>L</b>	
Circulation sensor .....	44, 104	Language .....	42, 100
Circulation time .....	90	Legionella protection function .....	86, 89
Commissioning .....	99	Legionella time .....	88
Condensing boilers .....	61	Liability .....	5
Configuration .....	43, 44	Low temperature boilers .....	61
Consumption .....	14	<b>M</b>	
Contact sensor .....	24	Main switch .....	22
Control centre .....	93, 101	Max. DHW temperature .....	81
<b>D</b>		Max. pump speed .....	60
De-couple control .....	43	Max. supply temperature .....	54
DHW boost .....	83	Menu key .....	25
DHW load circuit .....	11	Menu structure .....	30, 34
DHW load pump .....	51	Min. supply temperature .....	53
DHW load time .....	84	Mixer .....	23, 44, 51
DHW sensor .....	24, 104	Mixer parameter .....	57
DHW switch differential .....	82	Moon .....	26
Dial knob .....	25	<b>N</b>	
<b>E</b>		Night setback operation .....	26, 74
EBUS connection .....	23, 24	Normal operation .....	26, 50
EBUS terminal .....	19	<b>O</b>	
Electrical data .....	14	Operating display WCM-EM .....	27
Emergency operation .....	97, 99	Operating panel .....	25
End user level .....	25, 28	Output test .....	51
Error code .....	102, 103	<b>P</b>	
Error history .....	48, 49, 102	Parameter .....	34, 40
External sensor .....	23, 43, 44, 47, 52, 58, 104	Presence and absence key .....	25
External temperature .....	48	Priority .....	55
<b>F</b>		Pump heating circuit .....	8
Factory presetting .....	26, 30, 34, 39, 40, 45, 95, 96	Pump shut off set .....	24
Frost heating operation .....	74	<b>R</b>	
Frost protection .....	58	Ratings losses .....	56
Frost protection limit .....	74, 75	Reset .....	27, 76, 97, 98, 99
Function key .....	25	Room factor-P .....	80
Fusing .....	14	Room sensor .....	16, 19, 47
<b>G</b>		Room setpoint temperature .....	76
Gradient .....	79	Room thermostat .....	78
Guarantee .....	5		

**10 Key word index**

**S**

Safety measures ..... 6  
 Screed day ..... 68  
 Screed program ..... 65  
 Sensor tolerance ..... 52  
 Sensor variables ..... 104  
 Set factory presetting ..... 29, 33  
 Setback operation ..... 50, 74  
 Software version ..... 48  
 Solar utilisation ..... 85  
 Speed variable ..... 61  
 Standard display ..... 26  
 Standby ..... 26, 50  
 Storage ..... 14  
 Sun ..... 26  
 Supply sensor ..... 23  
 Supply voltage ..... 14  
 Switch on optimisation ..... 76  
 Symbol type of operation ..... 26  
 System example ..... 8, 9, 10, 11  
 System information ..... 48

**T**

Temperature ..... 14  
 Time bar program ..... 26  
 Time cursor ..... 93  
 Transport ..... 14  
 Type key ..... 7  
 Type of building ..... 77  
 Type of control ..... 47  
 Type of operation ..... 26

**U**

Umbrella ..... 26

**V**

Voltage supply ..... 14







**W**

Wall bracket ..... 16  
 Water tap ..... 26  
 Weather compensation ..... 23  
 WTC delay ..... 62

**Z**

Zone control ..... 23, 52, 58



Product		Description	Performance
	<b>W-Burners</b>	The compact series, proven millions of times over: Economical, reliable, fully automatic. Gas, oil and dual fuel burners for domestic and commercial applications. The purflam burner gives almost soot-free combustion of oil with greatly reduced NO <sub>x</sub> emissions.	Up to 570 kW
	<b>Monarch and industrial burners</b>	The legendary industrial burner: Tried and tested, long lived, clear construction. Gas, oil and dual fuel burners for district heat provision.	Up to 11,700 kW
	<b>multiflam® burners</b>	Innovative Weishaupt technology for large burners: Minimal emission values particularly at ratings over one megawatt. Oil, gas and dual fuel burners with patented fuel distribution system.	Up to 17,000 kW
	<b>WK industrial burners</b>	Modular powerhouses: Adaptable, robust, powerful. Oil, gas and dual fuel burners for industrial plant.	Up to 22,000 kW
	<b>Thermo Unit</b>	The Thermo Unit heating systems from cast iron or steel: Modern, economic, reliable. For environmentally friendly heating. Fuel: Gas or oil as desired.	Up to 55 kW
	<b>Thermo Condens</b>	The innovative condensing boilers with the SCOT system: Efficient, low in emissions, versatile. Ideal for domestic heating. Floor standing gas condensing boiler with ratings of up to 1200 kW (cascade), for higher heat demands.	Up to 1,200 kW
	<b>Heat pumps</b>	The heat pump programme offers solutions for utilisation of heat from air, soil and ground water. The systems are suitable for refurbishment or new builds. It is possible to use several heat pumps in cascade operation.	Up to 130 kW
	<b>Solar systems</b>	Free energy from the sun: Perfectly coordinated components, innovative, proven. Pleasantly shaped flat roof collectors to support heating and of domestic water	
	<b>Water heater / energy reservoir</b>	The attractive domestic water heating range includes classic water heaters which are supplied through a heating system and energy reservoirs which can be fed through solar systems.	
	<b>Control technology / building management</b>	From control panels to complete building management systems – at Weishaupt you can find the entire spectrum of modern control technology. Future oriented, economical and flexible.	